

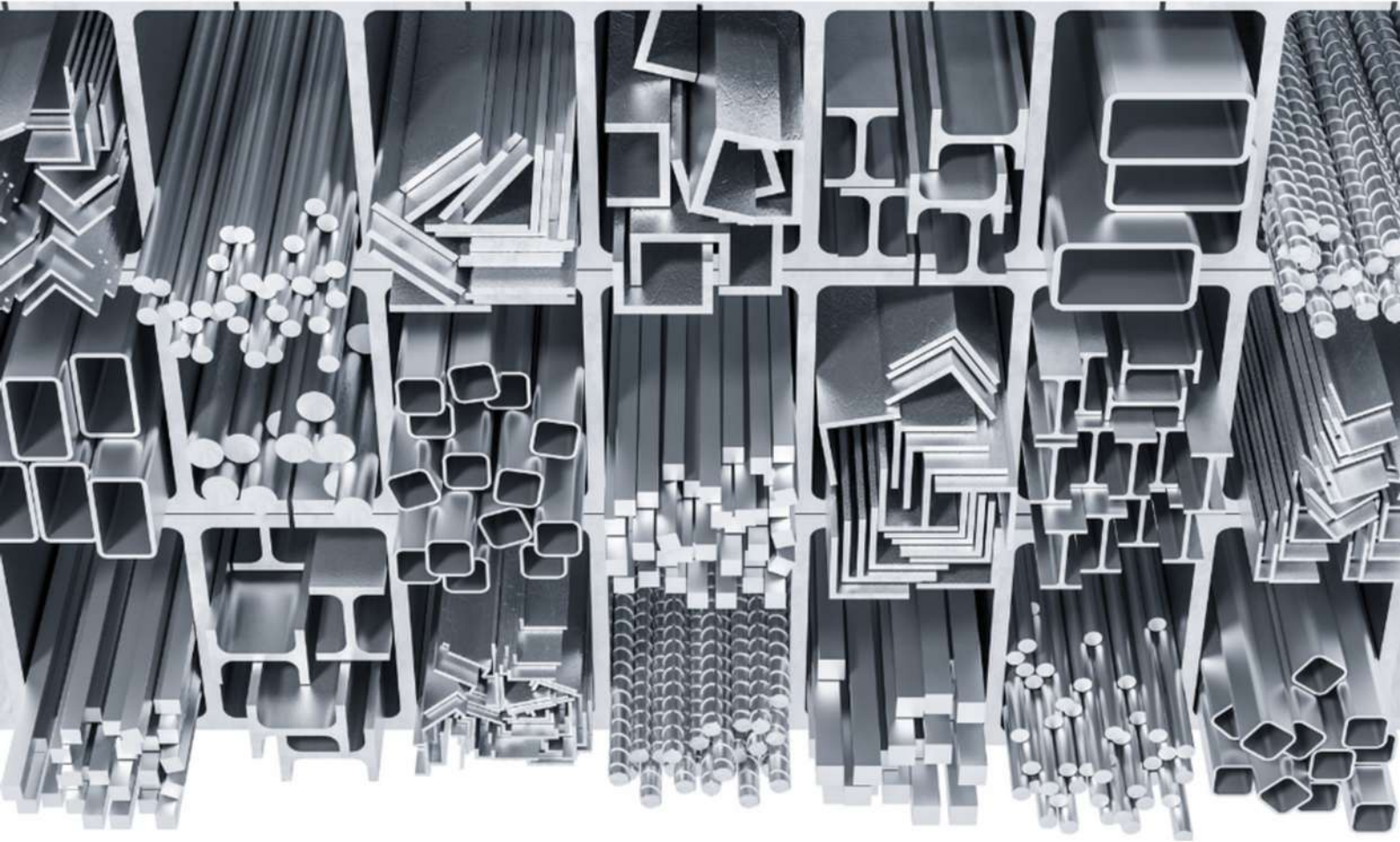

# ***All Metal Industries***

## **Aluminium Products Catalogue** **Stocked Products** **2023**



# Company Introduction



## ***All Metal Industries***

All Metal Industries is Western Australia's premier metal distribution company, with a reputation for reliable supply, strong stock levels and supporting businesses of all sizes with supply of aluminium extrusions, castings, stainless steel mesh and specialist steel products.

Locally owned and operated, our primary focus is on developing strong customer relationships and supply agreements, allowing us to provide high quality and cost-effective supply of materials to a vast range of industries and markets across Australia. Our unwavering commitment to being the best at what we do has allowed us to establish ourselves as a leading stockholder of aluminium and metal distributor in Western Australia.

With the ongoing volatility of the market, we partner with our customers to understand their business and ensure our products and services remain relevant to their needs and provide them with a competitive advantage. Along with offering an extensive range of stocked solutions, we are also able to develop specific products, tailored to the individual needs of our customers and their project.

Primary industries we support:

- Engineering & Fabrication
- Fencing
- Building & Façade
- Transport
- Resource & Construction

With integrity and innovation at the foundation of our operations, All Metal Industries are committed to the reliable provision of products tailored to the needs of your business. Through continuous improvement and investment, All Metal Industries strives for excellence across service, pricing and quality of products, now and into the future.

Matthew Wimmer  
Managing Director



1-2	Tech-1 Modular Sun Blade
3-5	Tech-2 Operable/Fixed 88mm Louvre Blade system
6-8	Tech-3 Mechanical Louvre System
9-13	Tech-4 Fencing Sections
14-16	Cool Room / Transportable Sections
17-18	Signage Sections
19-22	Geometric Sections
23-25	Castings, Endcaps and Brackets
26-27	Gate Hardware
28-29	Gate Automation
30-31	Processing Hardware





**All Metal Industries**

**Tech-1 Modular Sun-Blade System**  
**Stocked Products**

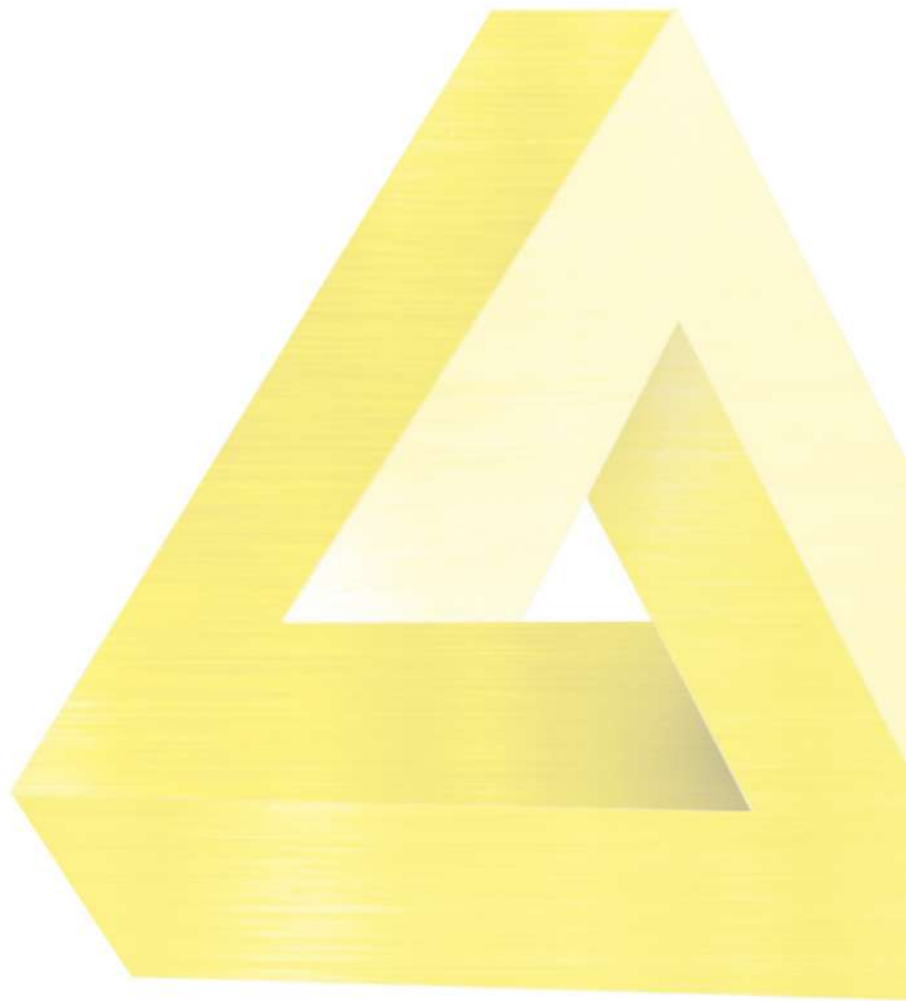

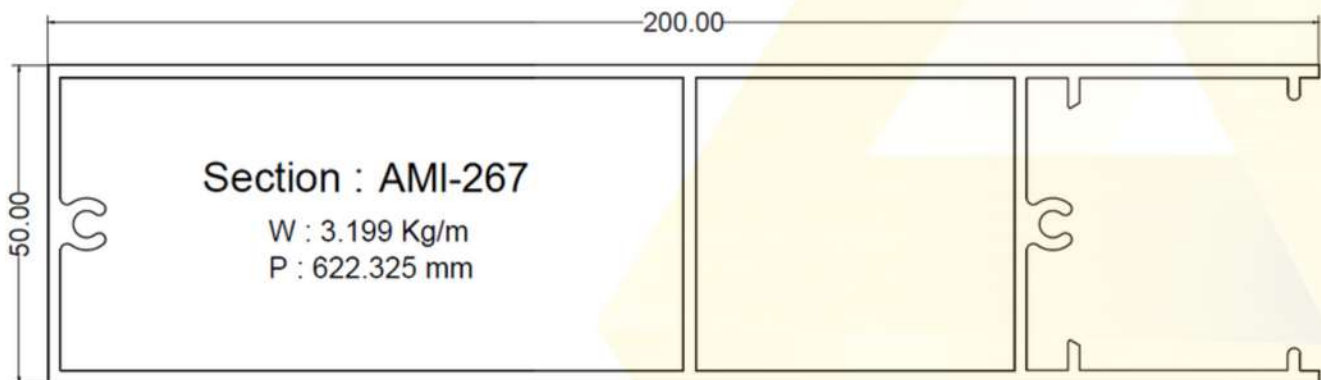
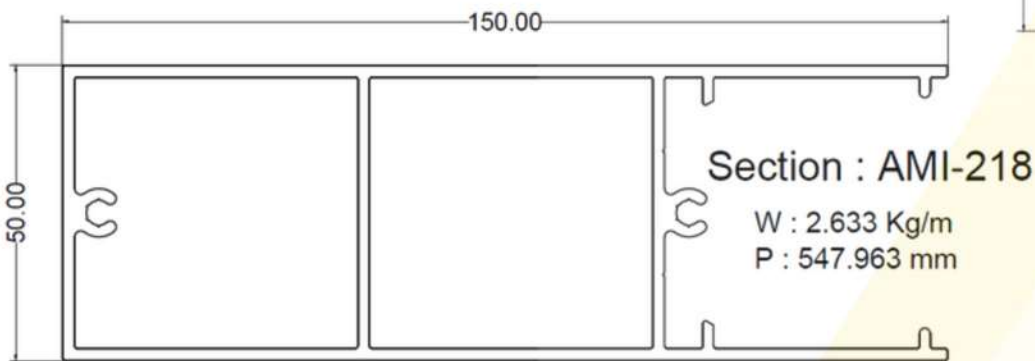
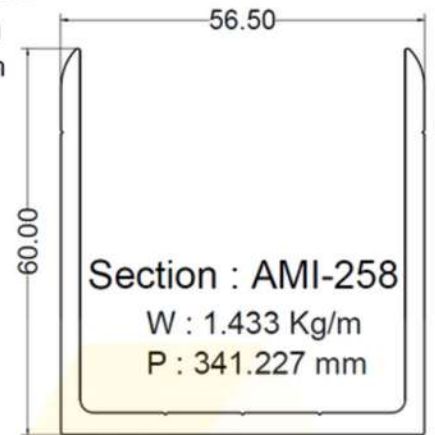
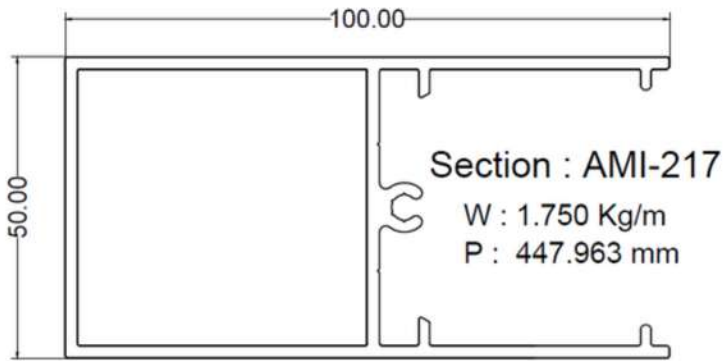
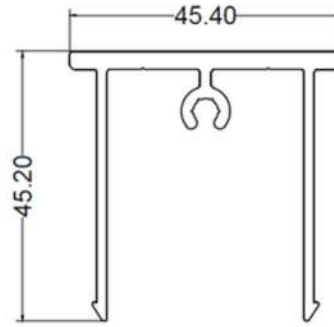
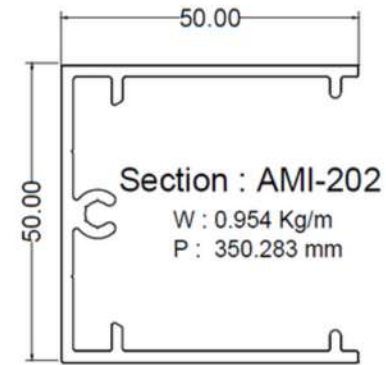



**All Metal Industries**

**Tech-2 Operable/Fixed 88mm Louvre System  
Stocked Products**

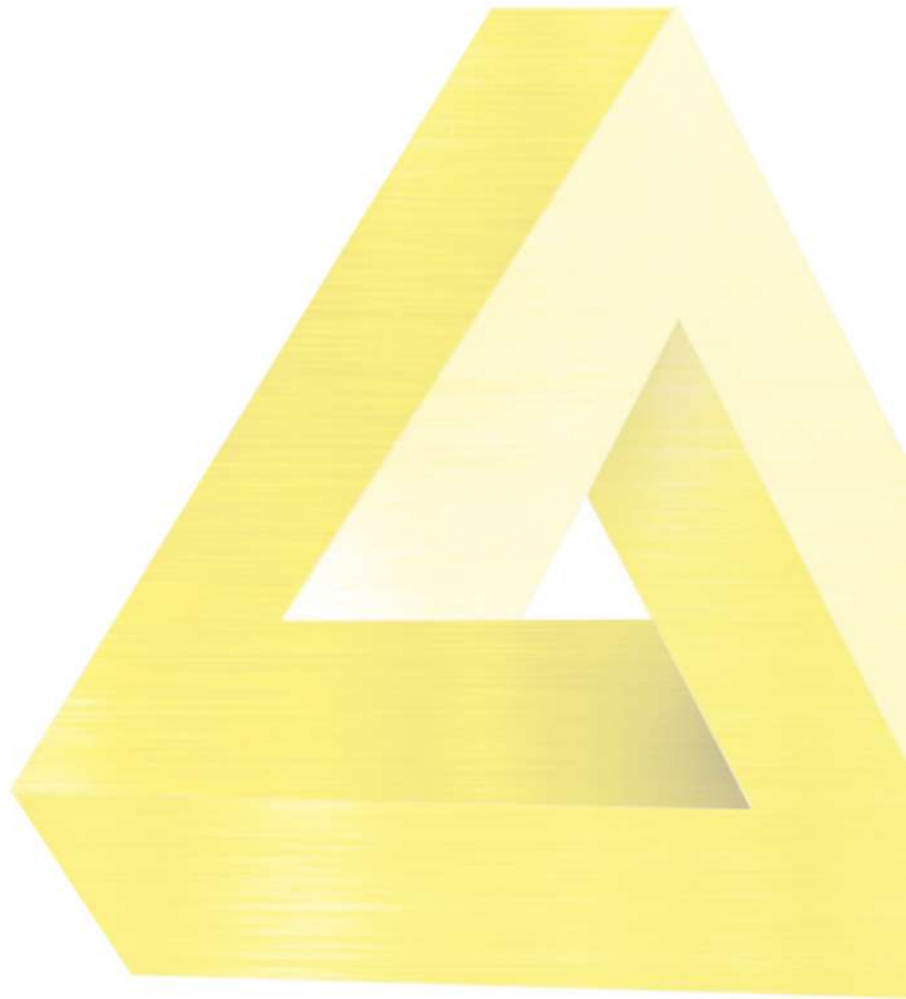

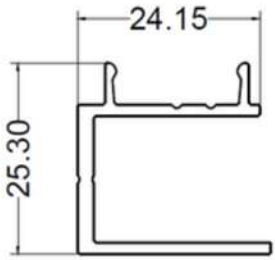

**Section : AMI-129**

W : 0.333 Kg/m  
P : 155.94 mm

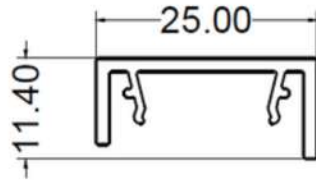

**Section : AMI-130**

W : 0.211 Kg/m  
P : 114.80 mm

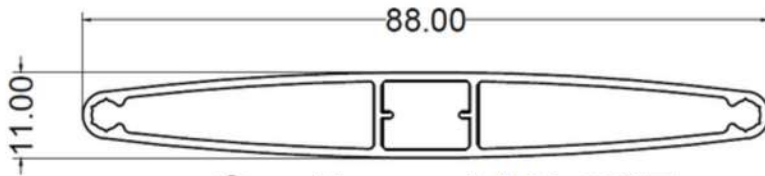

**Section : AMI-227**

W : 0.609 Kg/m  
P : 183.26 mm

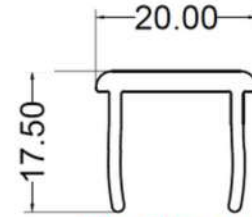

Pre-Punched

**Section : AMI-233**

W : 0.252 Kg/m  
P : 101.35 mm

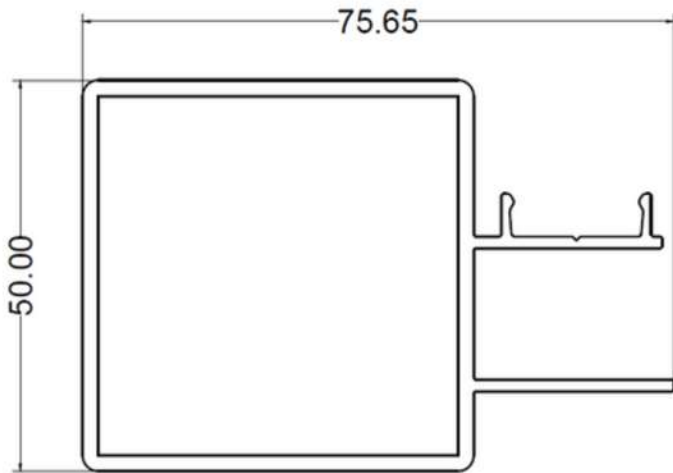

**Section : AMI-135**

W : 1.269 Kg/m  
P : 316.60 mm

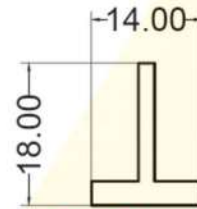

Pre-Punched  
Louvre Handle

**Section : AMI-251**

W : 0.195 Kg/m  
P : 64.00 mm

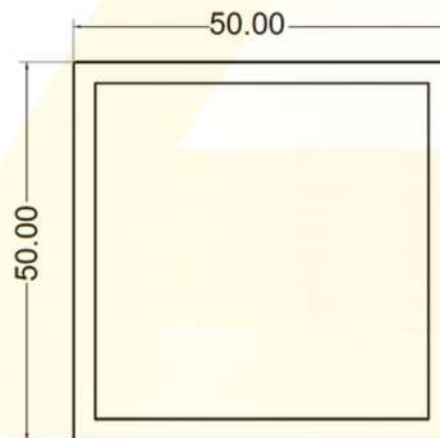

Pre-punched

**Section : AMI-1243**

W : 1.523 Kg/m  
P : 200.00 mm



## Single & Double Side Punched

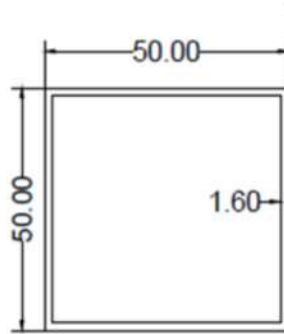
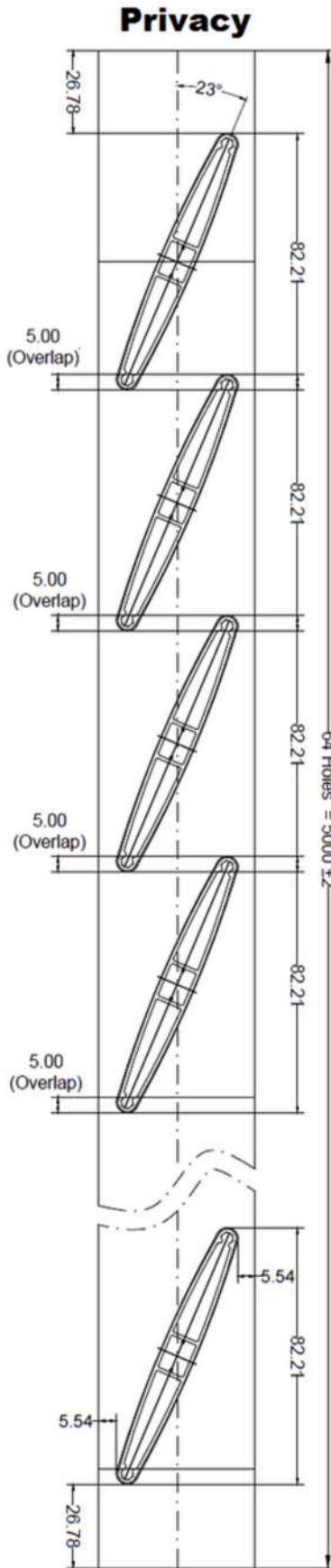

### Section : AMI-1241

W : 0.837 Kg/m  
P : 200 mm

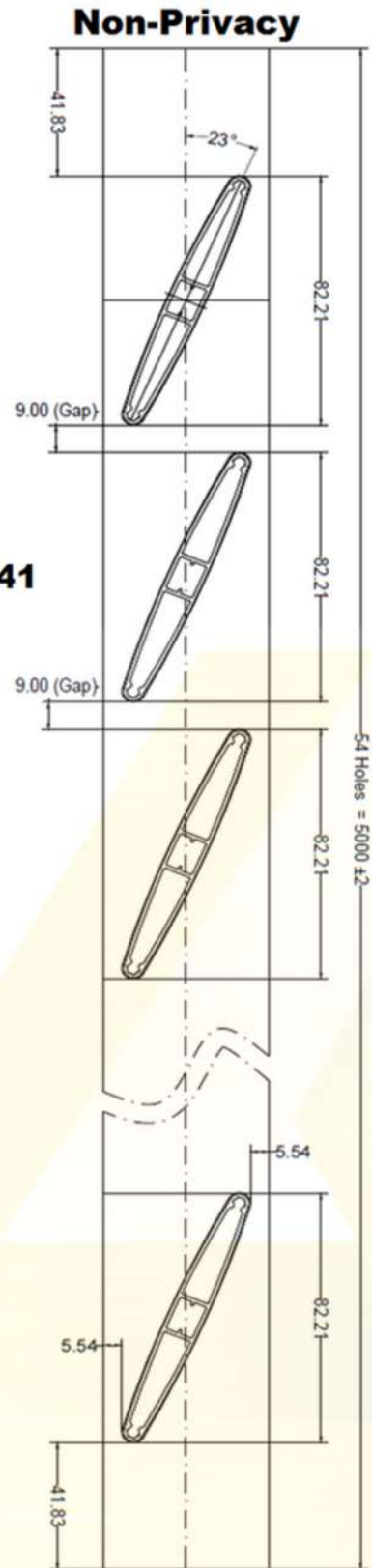





**All Metal Industries**

**Tech-3 Mechanical Louvre System**  
**Stocked Products**

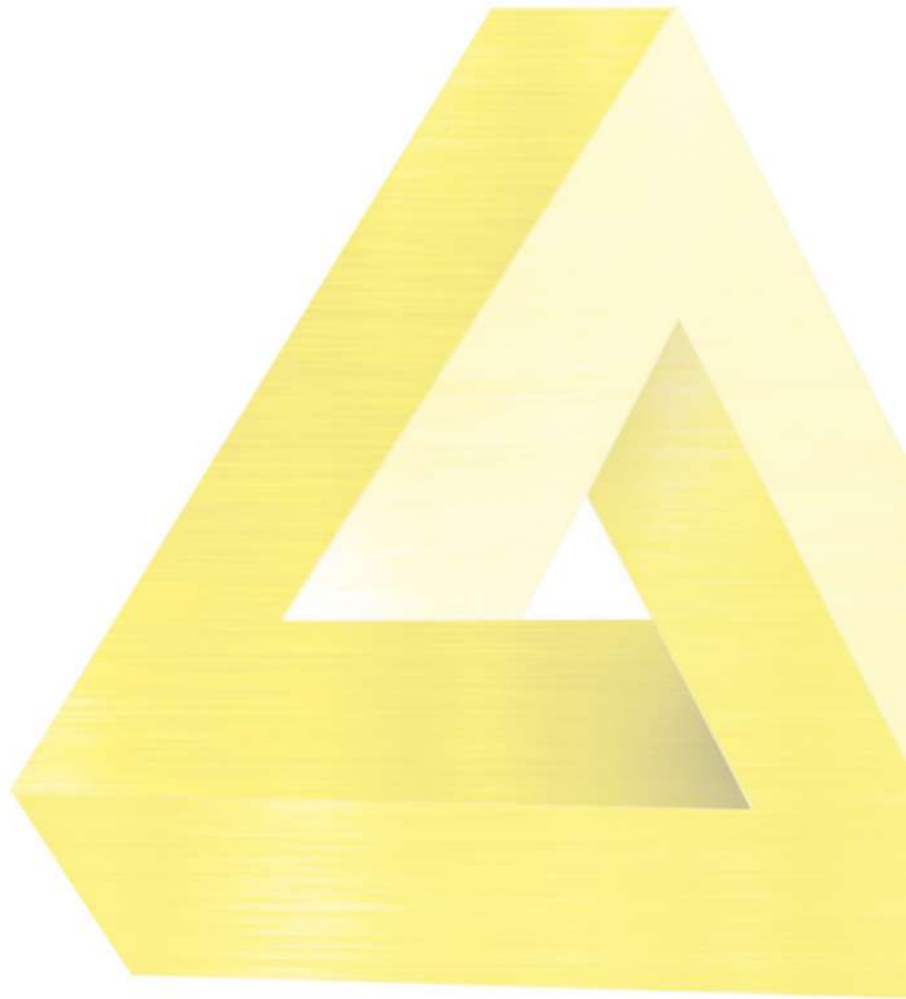

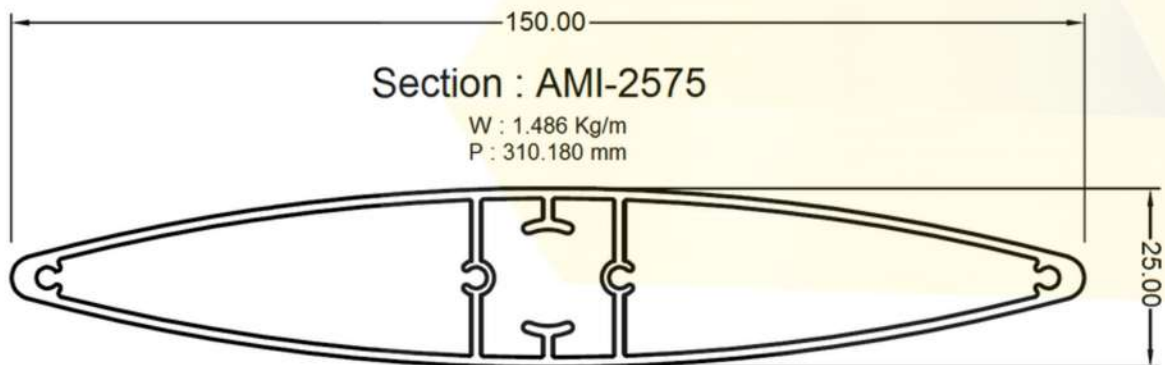
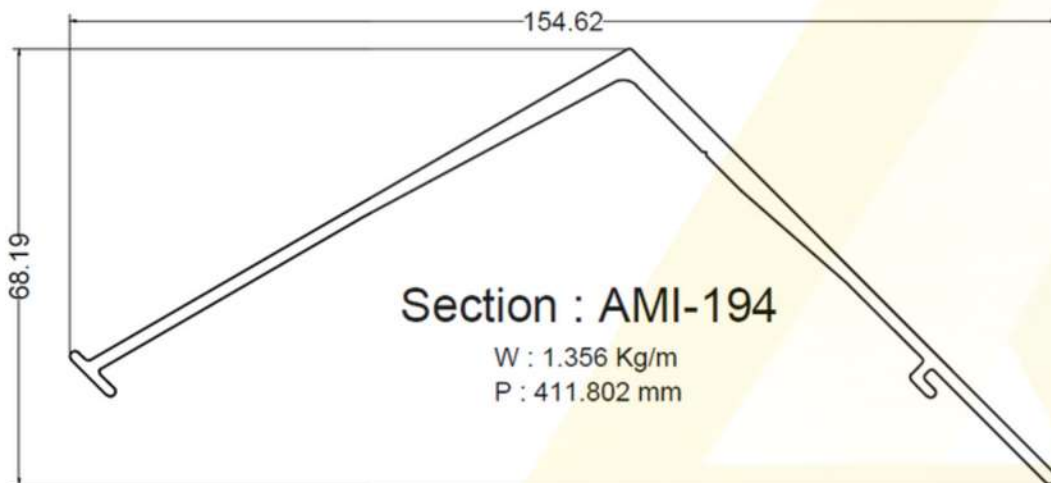
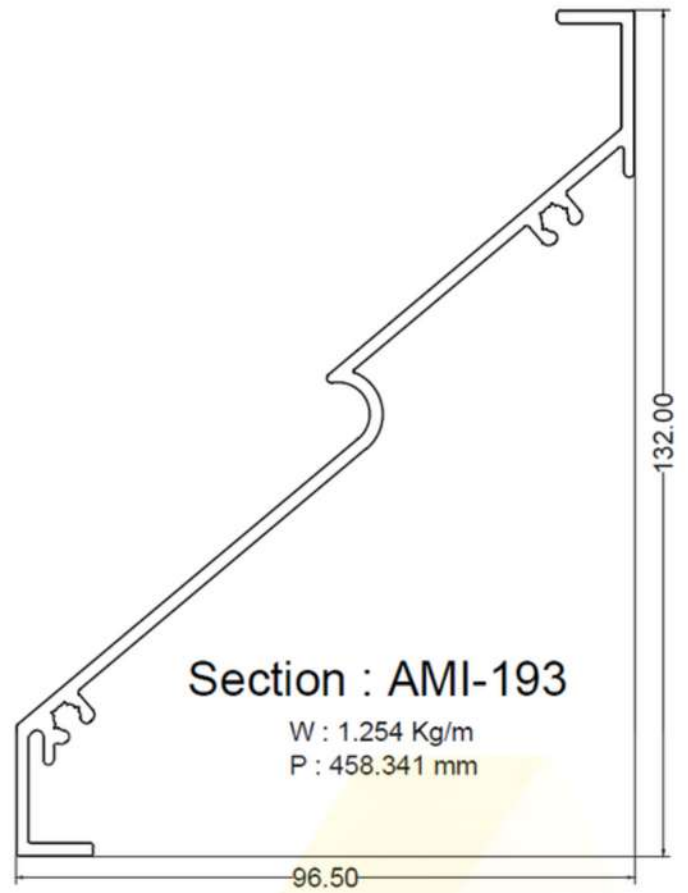
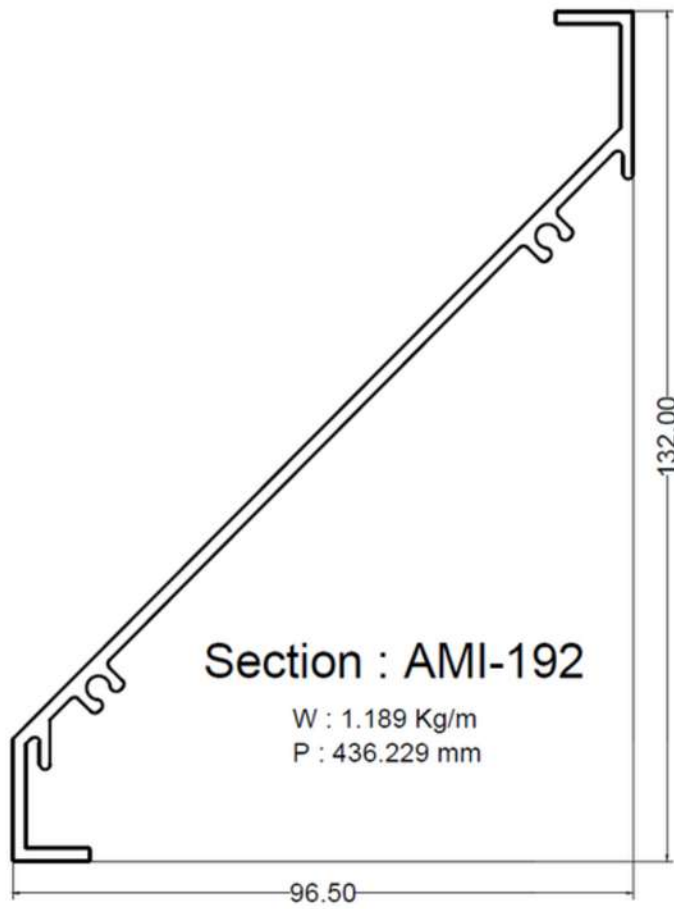

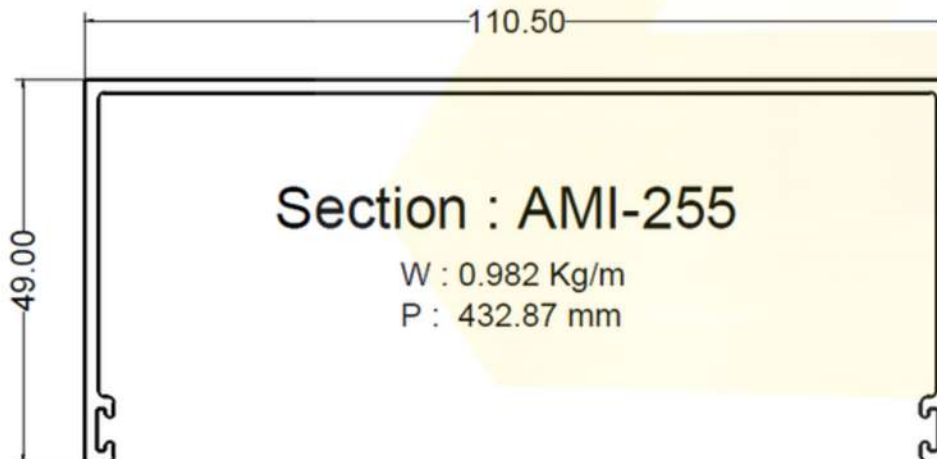
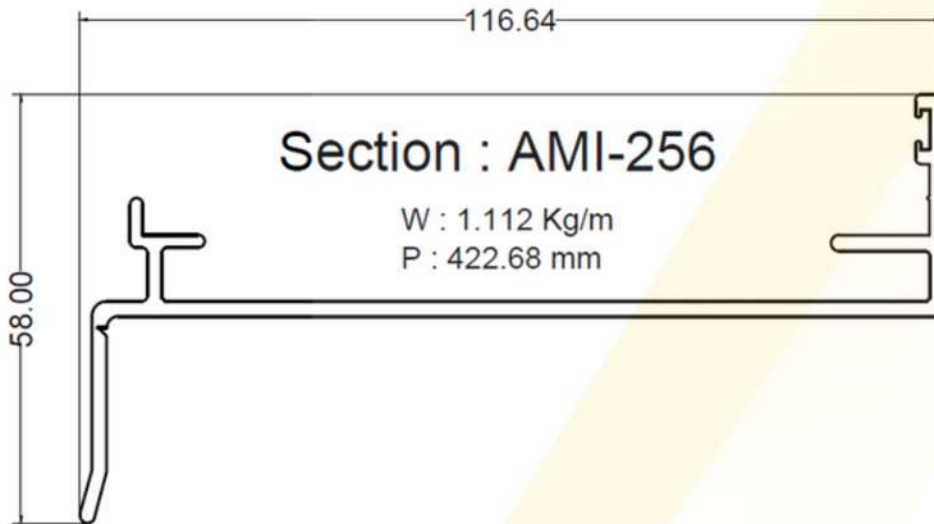
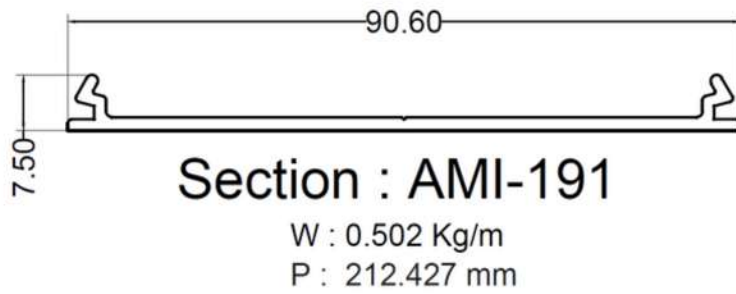
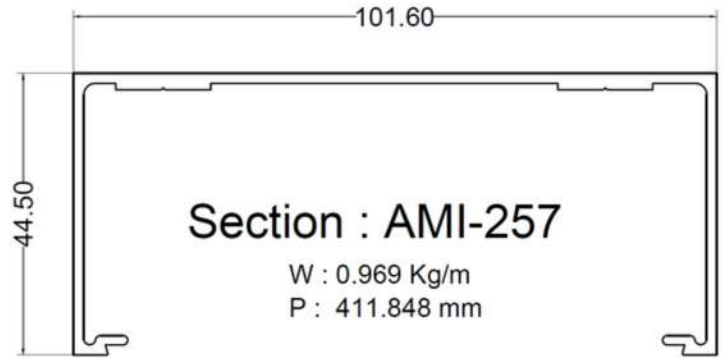
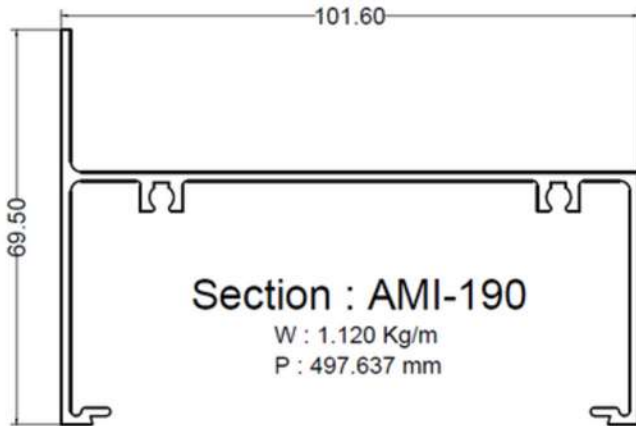



**All Metal Industries**

**Tech-4 Fencing Sections**  
**Stocked Products**

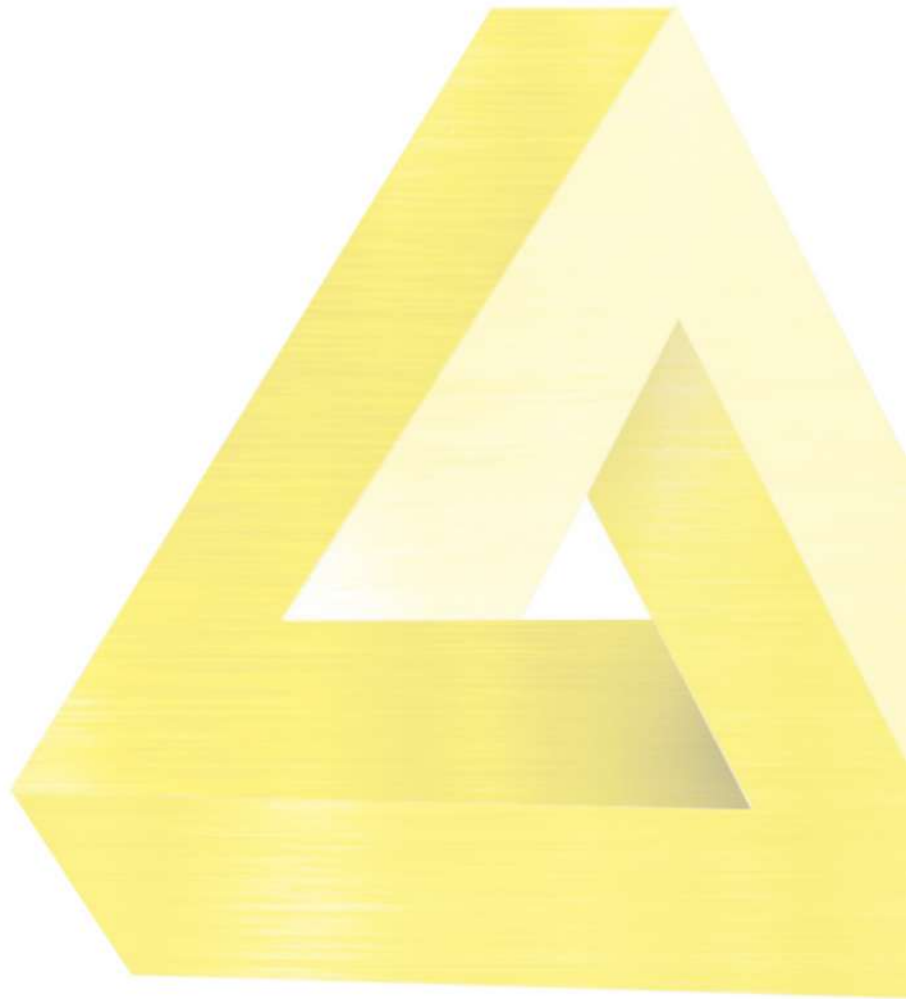

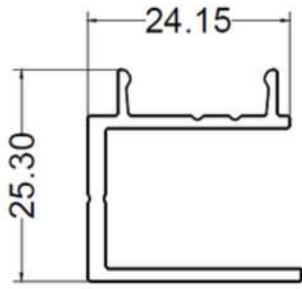

**Section : AMI-129**

W : 0.333 Kg/m  
P : 155.94 mm

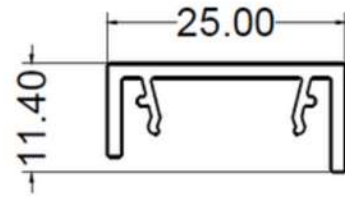

**Section : AMI-130**

W : 0.211 Kg/m  
P : 114.80 mm

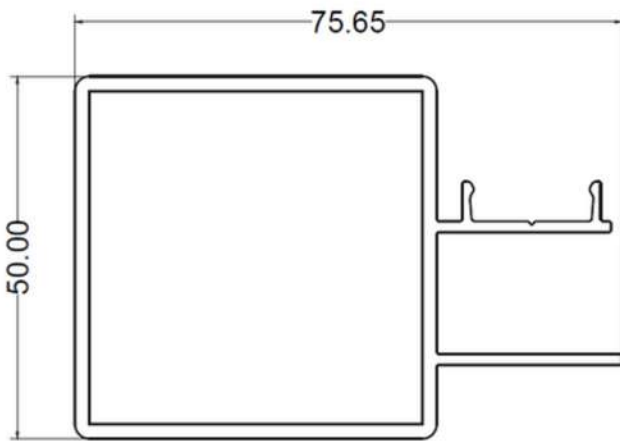

**Section : AMI-134**

W : 1.269 Kg/m  
P : 316.60 mm

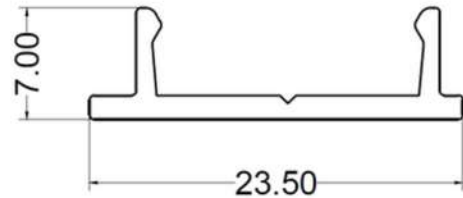

**Section : AMI-163**

W : 0.131 Kg/m  
P : 71.209 mm

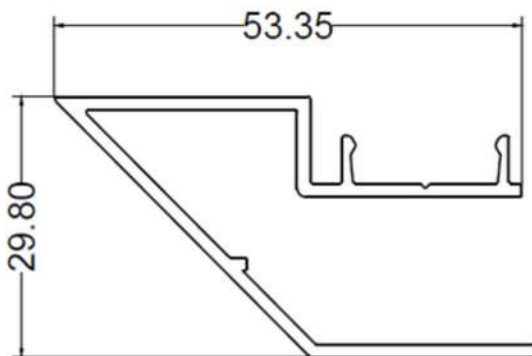

**Section : AMI-175**

W : 0.557 Kg/m  
P : 277.70 mm

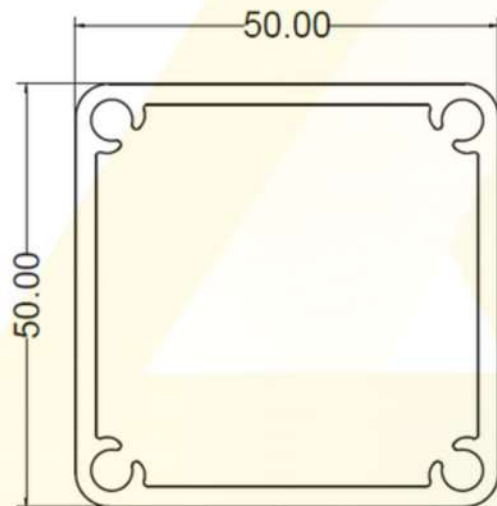

**Section : AMI-162**

W : 1.271 Kg/m  
P : 193.133 mm

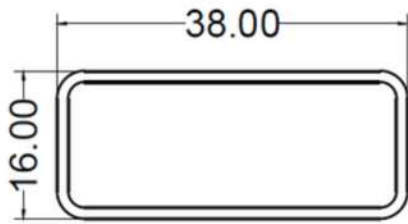

Section : AMI-1601

W : 0.322 Kg/m

P : 102.85 mm

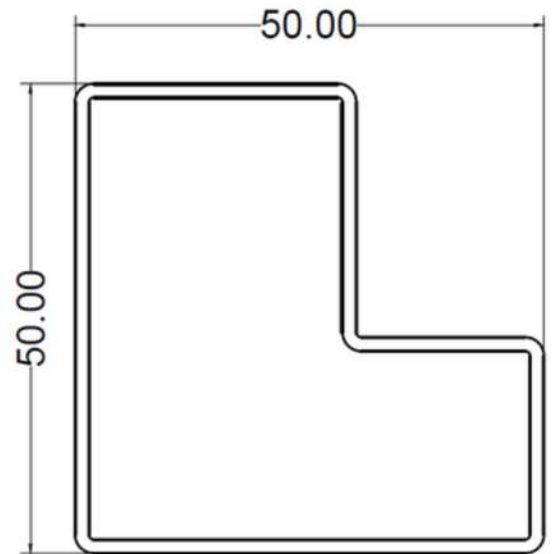

Section : AMI-121

W : 0.776 Kg/m

P : 195.50 mm

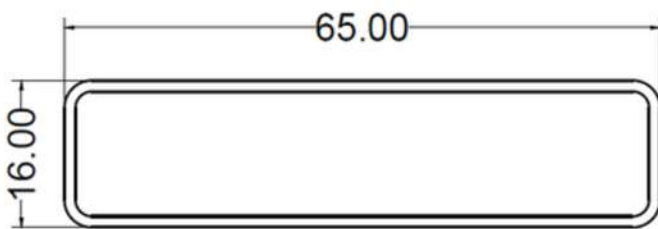

Section : AMI-1603

W : 0.496 Kg/m

P : 156.90 mm

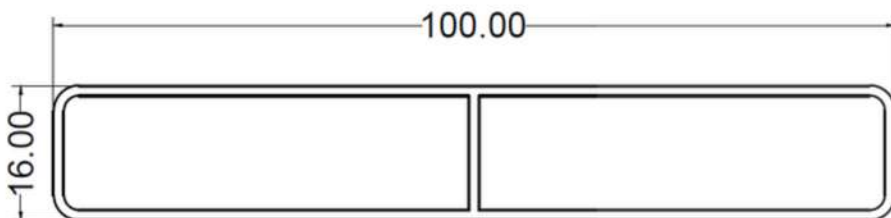

Section : AMI-012

W : 0.770 Kg/m

P : 226.85 mm

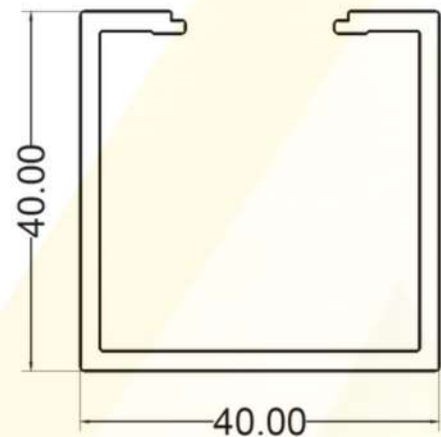

Section : AMI-261

W : 0.799 Kg/m

P : 271.928 mm

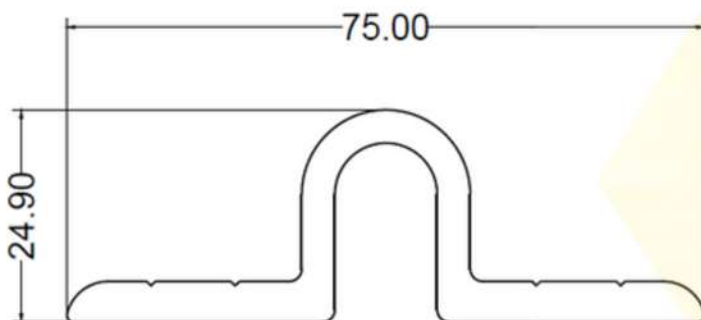

Section : AMI-243

W : 1.265 Kg/m

P : 222.48 mm

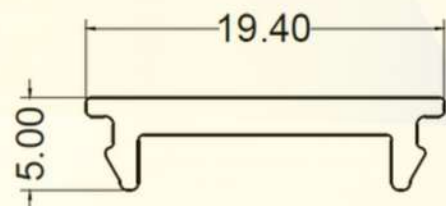

Section : AMI-262

W : 0.119 Kg/m

P : 53.045 mm

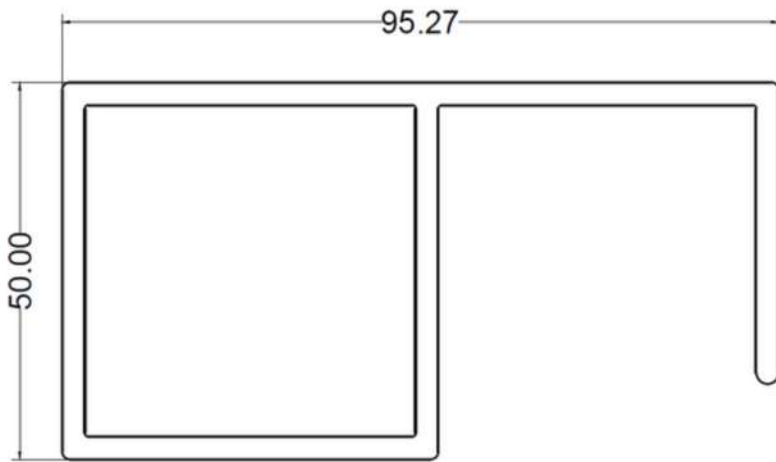

## Section : AMI-2567

W : 2.193 Kg/m

P : 361.10 mm

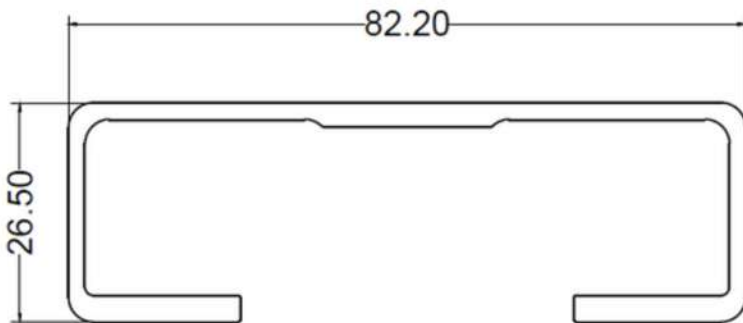

## Section : AMI-241

W : 1.083 Kg/m

P : 333.40 mm

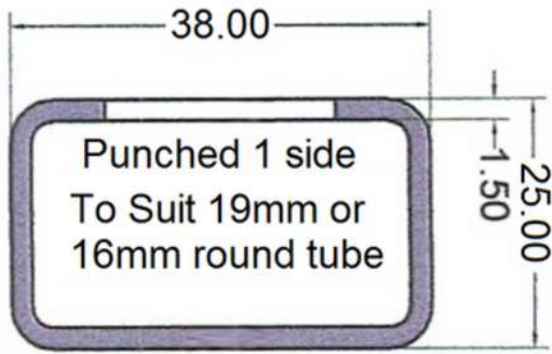

Section : AMI-2883

W : 0.473 Kg/m

P : 120.84 mm

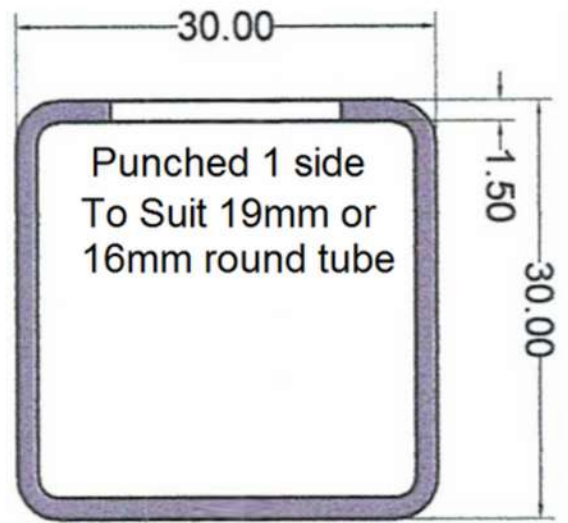
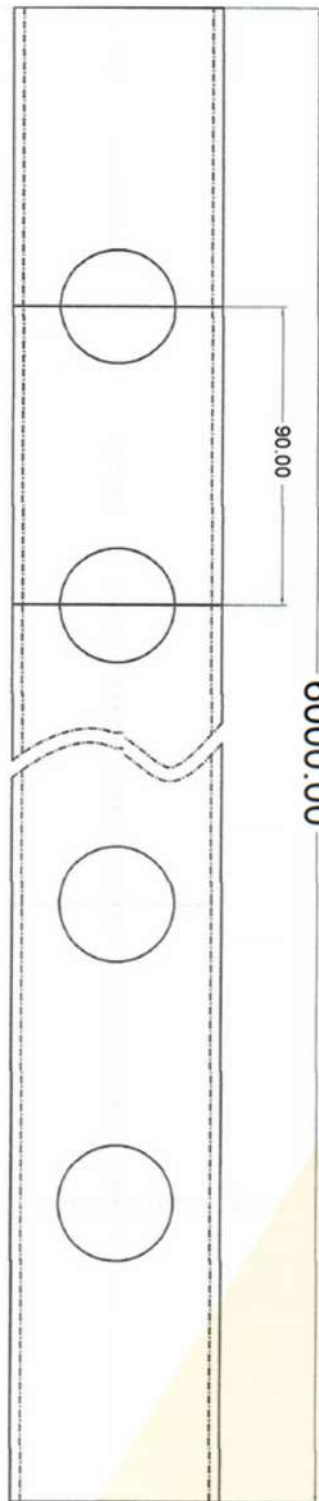
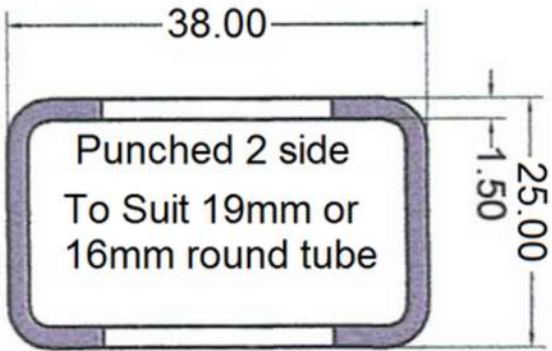

Section : AMI-2784

W : 0.448 Kg/m

P : 114.85 mm

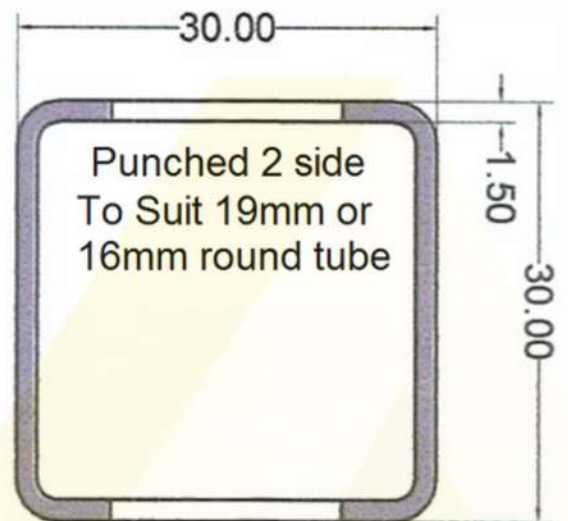





**All Metal Industries**

**Coolroom / Transportable Sections**  
**Stocked Products**

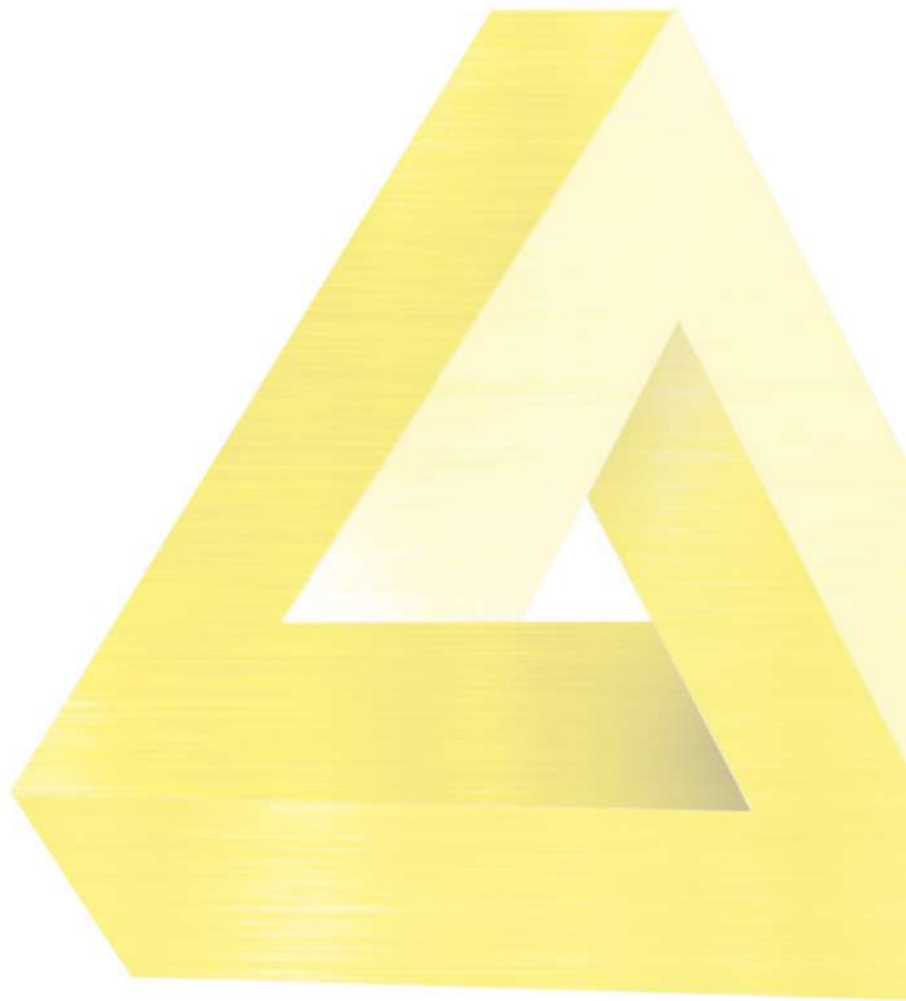

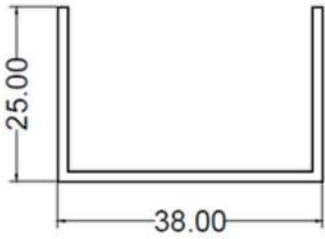

**Section : AMI-002**

W : 0.323 Kg/m  
P : 173.20 mm

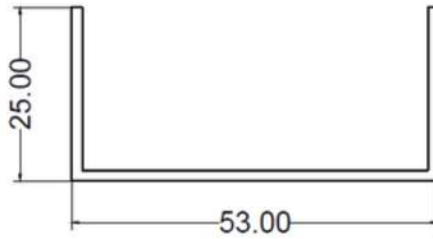

**Section : AMI-004**

W : 0.406 Kg/m  
P : 203.00 mm

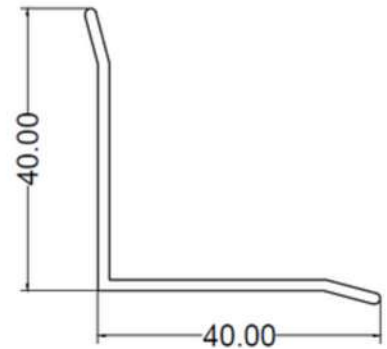

**Section : AMI-001**

W : 0.341 Kg/m  
P : 159.628 mm

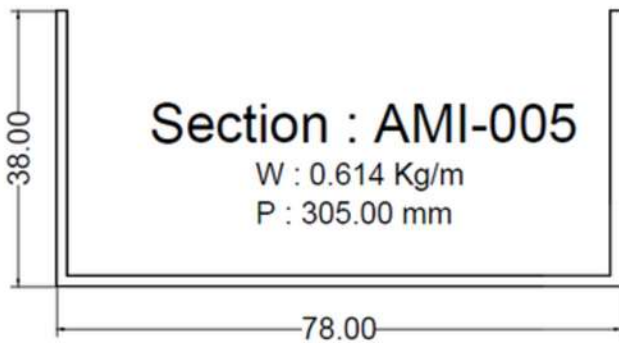

**Section : AMI-005**

W : 0.614 Kg/m  
P : 305.00 mm

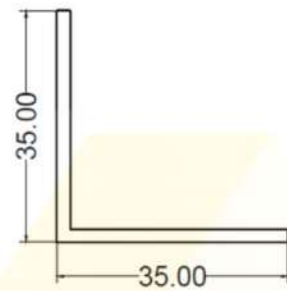

**Section : AMI-036**

W : 0.369 Kg/m  
P : 140.00 mm

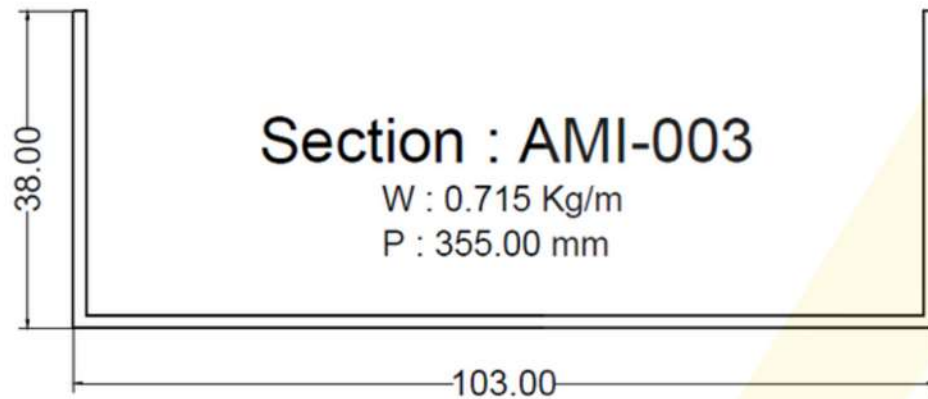

**Section : AMI-003**

W : 0.715 Kg/m  
P : 355.00 mm

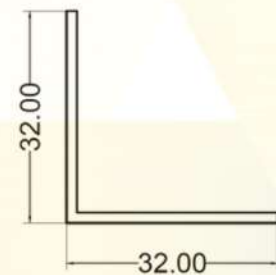

**Section : AMI-1388**

W : 0.271 Kg/m  
P : 128.00 mm

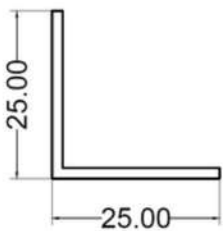

**Section : AMI-1381**

W : 0.210 Kg/m  
P : 100.00 mm

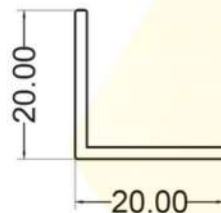

**Section : AMI-1376**

W : 0.166 Kg/m  
P : 79.40 mm

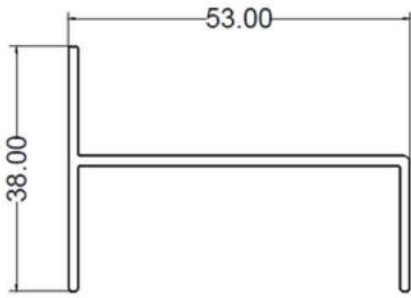

Section : AMI-046

W : 0.442 Kg/m  
P : 219.15 mm

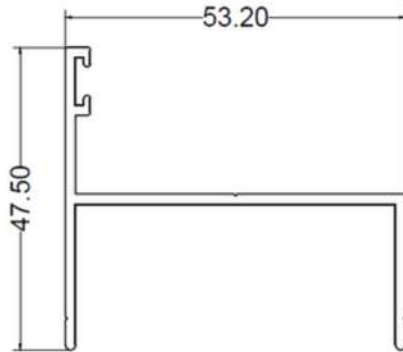

Section : AMI-082

W : 0.552 Kg/m  
P : 260.269 mm

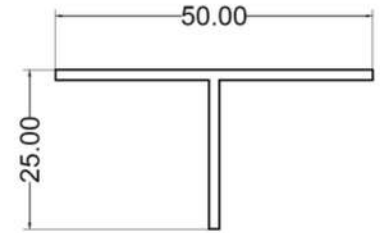

Section : AMI-1690

W : 0.318 Kg/m  
P : 150.00 mm

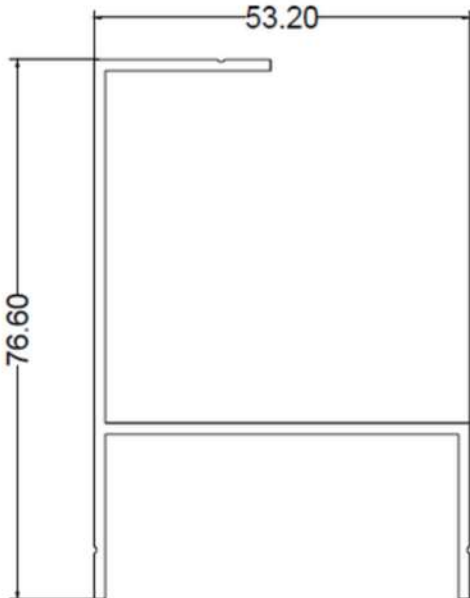

Section : AMI-080

W : 0.753 Kg/m  
P : 352.00 mm

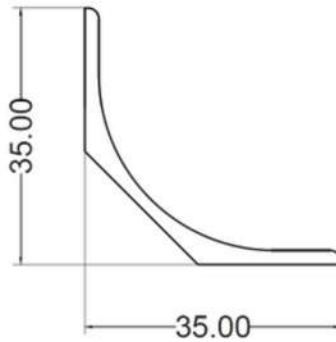

Section : AMI-260

W : 0.359 Kg/m  
P : 119.366 mm

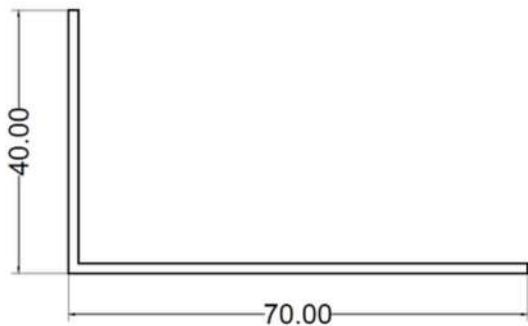

Section : AMI-1447

W : 0.441 Kg/m  
P : 220.00 mm

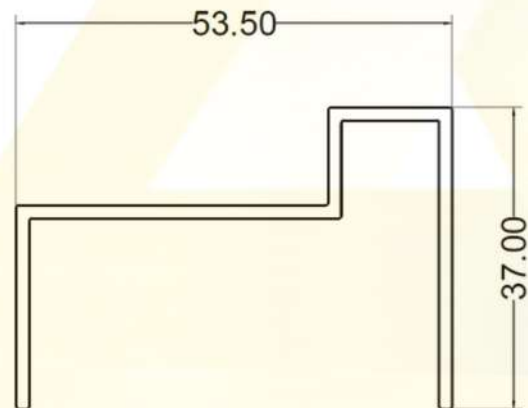

Section : AMI-048

W : 0.539 Kg/m  
P : 250.26 mm



**All Metal Industries**

**Signage Sections**  
**Stocked Products**

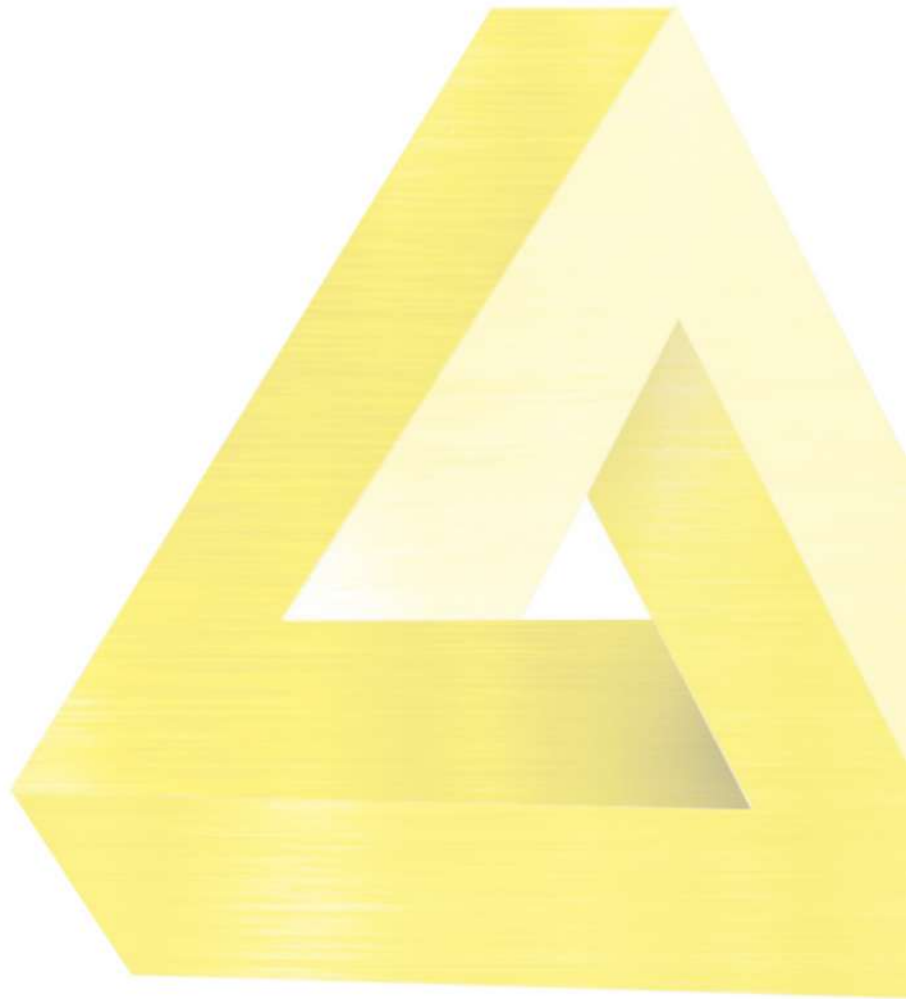

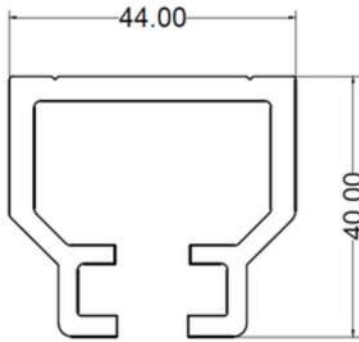

**Section : AMI-211**

W : 1.368 Kg/m  
P : 295.347 mm

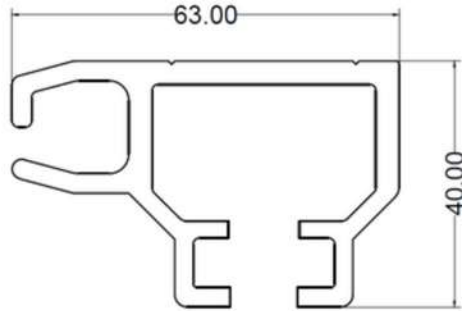

Available on request  
**Section : AMI-210**

W : 1.756 Kg/m  
P : 376.23 mm

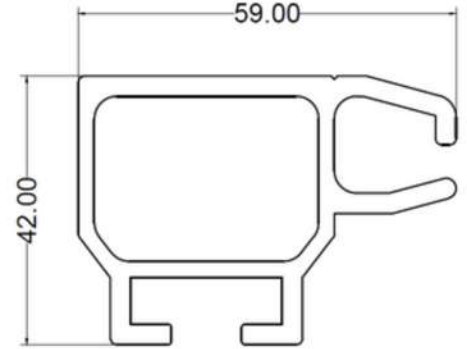

Available on request  
**Section : AMI-212**

W : 1.612 Kg/m  
P : 281.633 mm

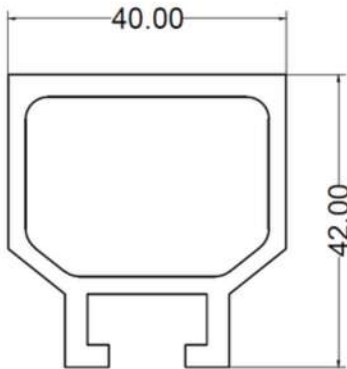

Available on request  
**Section : AMI-213**

W : 1.237 Kg/m  
P : 202.03 mm

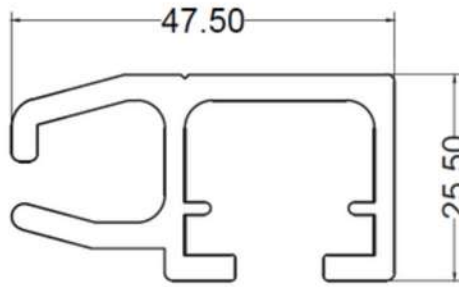

Available on request  
**Section : AMI-344**

W : 1.072 Kg/m  
P : 265.00 mm

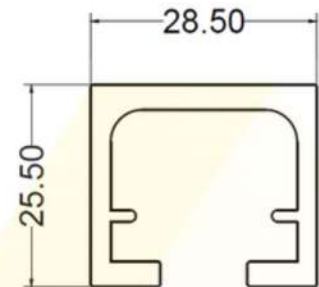

**Section : AMI-348**

W : 0.698 Kg/m  
P : 184.70 mm

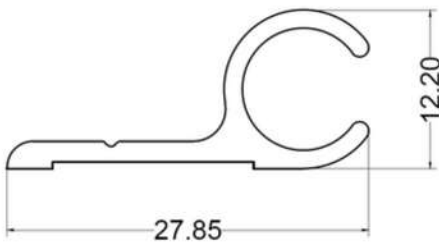

**Section : AMI-8738**

W : 0.202 Kg/m  
P : 94.054 mm



**All Metal Industries**

**Geometric Sections**  
**Stocked Products**

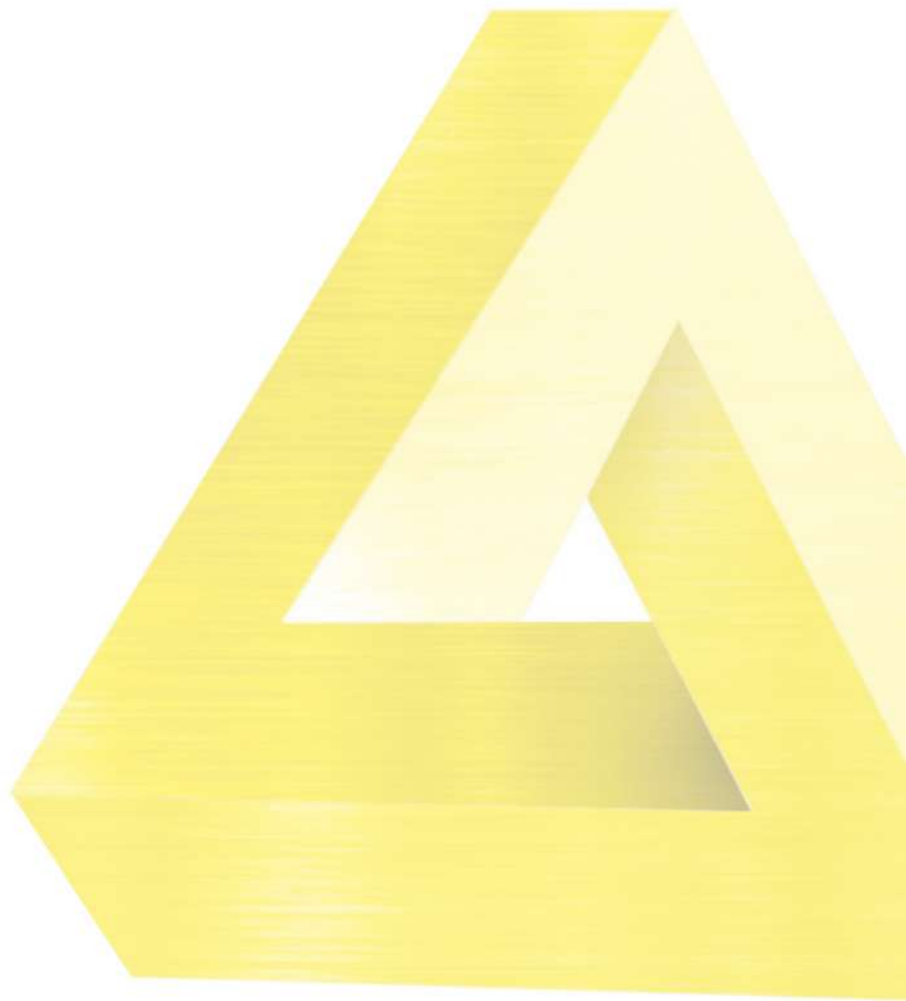



### Flat Bar

Section Code	Size	Weight per/M	Perimeter	Length (M)
AMI-1318	25 x 3	0.203	56.00	4.0
AMI-10010	40 x 6	0.650	92.00	4.0
AMI-1332	40 x 10	1.084	100.00	4.0
AMI-1335	50 x 3	0.406	105.50	4.0
AMI-1336	50 x 6	0.814	112.00	4.0
AMI-8252	50 x 8	1.084	116.00	4.0
AMI-1337	50 x 10	1.355	120.00	4.0
AMI-1011	80 x 6	1.301	172.00	4.0
AMI-1356	100 x 3	0.813	206.00	4.0
AMI-1098	100 x 6	1.626	212.00	4.0
AMI-1358	100 x 10	2.710	220.00	4.0
AMI-1060	100 x 20	5.420	240.00	4.0

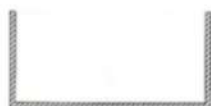

### U-Channel

Section Code	Size	Weight per/M	Perimeter	Length (M)
AMI-1939	20 x 20 x 1.5	0.232	117.00	6.5
AMI-002	38 x 25 x 1.4	0.323	173.20	6.5
AMI-004	53 x 25 x 1.5	0.406	203.00	6.5
AMI-005	78 x 38 x 1.5	0.614	229.00	6.5
AMI-003	103 x 38 x 1.5	0.715	355.00	6.5



### Round Solid

Section Code	Size	Weight per/M	Perimeter	Length (M)
AMI-1482	12mm	0.320	37.70	4.0
AMI-1483	16mm	0.545	50.27	4.0



### Tee Bar

Section Code	Size	Weight per/M	Perimeter	Length (M)
AMI-1690	50 x 25 x 1.6	0.318	150.00	6.5
AMI-2488	75 x 25 x 1.6	0.545	200.00	6.5



### Square Solid

Section Code	Size	Weight per/M	Perimeter	Length (M)
AMI-1115	12 x 12	0.390	40.00	4.0



**Radius SHS**

Section Code	Size	Weight per/M	Perimeter	Length (M)
AMI-095	20 x 20 x 1.6	0.314	77.25	6.5
AMI-1638	25 x 25 x 1.6	0.404	98.28	6.5
AMI-2784	30 x 30 x 1.5	0.448	114.85	6.5
AMI-1651	40 x 40 x 3	1.140	149.70	6.5
AMI-1655	50 x 50 x 2	0.990	189.70	1.8 - 2.1 - 6.5
AMI-1656	50 x 50 x 3	1.466	189.70	1.8 - 2.4 - 6.5
AMI-1666	65 x 65 x 3	2.009	251.40	2.4 - 6.5
AMI-287	100 x 100 x 3	3.175	399.99	3 - 6.5



**Square Edge SHS**

Section Code	Size	Weight per/M	Perimeter	Length (M)
AMI-1236	40 x 40 x 1.6	0.667	160.00	6.5
AMI-1238	40 x 40 x 3	1.199	159.50	6.5
AMI-1242	50 x 50 x 2	1.040	200.00	6.5
AMI-1243	50 x 50 x 3	1.523	200.00	6.5
AMI-1252	75 x 75 x 3	2.341	300.00	6.5
AMI-1255	100 x 100 x 3	3.143	400.00	6.5
AMI-373	152.4 x 152.4 x 4.78	2.341	609.00	3.6



**Radius RHS**

Section Code	Size	Weight per/M	Perimeter	Length (M)
AMI-1601	38 x 16 x 1.2	0.322	102.85	6.5
AMI-2883	38 x 25 x 1.5	0.473	120.85	6.5
AMI-1603	65 x 16 x 1.2	0.498	156.90	6.5
AMI-219	65 x 50 x 3	1.710	219.70	6.5
AMI-012	100 x 16 x 1.2	0.770	226.85	6.5
AMI-008	100 x 50 x 3	2.279	289.70	6.5





### Square Edge RHS

Section Code	Size	Weight per/M	Perimeter	Length (M)
AMI-2890	40 x 20 x 3	0.878	120.00	6.5
AMI-0001	50 x 25 x 2	0.770	150.00	6.5
AMI-1188	60 x 40 x 3	1.530	199.48	6.5
AMI-1181	76.2 x 25.4 x 2.4	1.255	203.20	6.5
AMI-1195	75 x 50 x 3	1.930	250.00	6.5
AMI-1189	80 x 40 x 3	1.854	240.00	6.5
AMI-1172	100 x 25 x 2.5	1.626	250.00	6.5
AMI-1199	100 x 50 x 3	2.342	299.31	6.5
AMI-1202	150 x 50 x 3	3.155	400.00	6.5
AMI-1203	200 x 50 x 3	3.967	500.00	6.5



### Angles

Section Code	Size	Weight per/M	Perimeter	Length (M)
AMI-1376	20 x 20 x 1.6	0.166	79.40	6.5
AMI-1381	25 x 25 x 1.6	0.21	100.00	6.5
AMI-1436	32 x 20 x 1.6	0.218	104.00	6.5
AMI-1388	32 x 32 x 1.6	0.271	128.00	6.5
AMI-036	35 x 35 x 2	0.369	140.00	6.5
AMI-1395	40 x 40 x 3	0.626	159.40	6.5
AMI-1443	50 x 25 x 3	0.585	150.00	6.5
AMI-519	50 x 50 x 3	0.789	200.00	6.5
AMI-1402	50 x 50 x 6	1.53	200.00	6.5
AMI-1447	70 x 40 x 1.5	0.441	220.00	6.5
AMI-1451	100 x 50 x 3	1.195	300.00	6.5
AMI-1536	100 x 50 x 6	2.341	300.00	6.5



### Round Tube

Section Code	Size	Weight per/M	Perimeter	Length (M)
AMI-1267	16 x 1.2	0.151	50.27	6.5
AMI-1270	19 x 1.6	0.237	59.69	6.5
AMI-1288	40 x 3	0.946	125.66	6.5
AMI-1293	50 x 3	1.202	157.08	6.5
AMI-8523	101.6 x 1.6	1.362	319.19	6.5





**All Metal Industries**

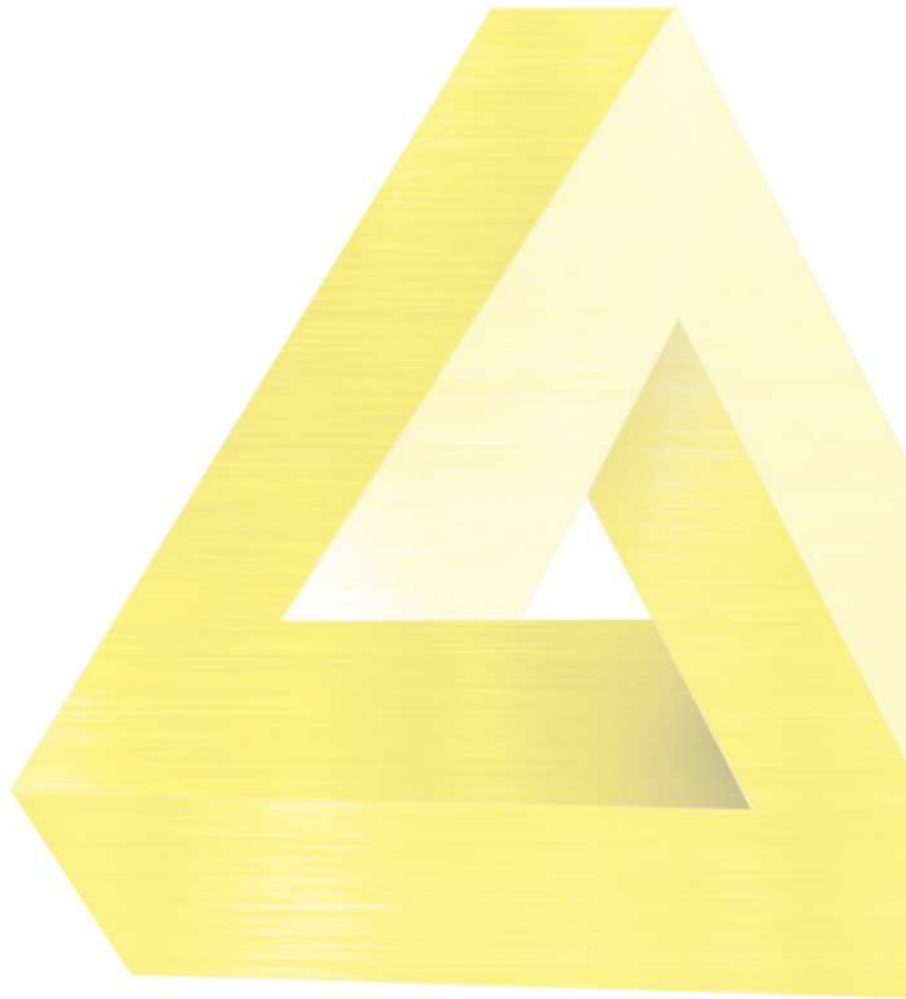

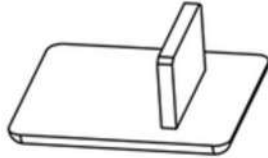
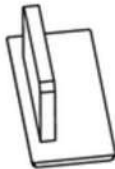
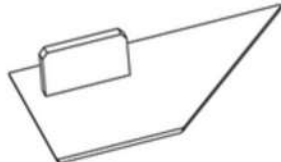

**Castings, Endcaps and Brackets**  
**Stocked Products**

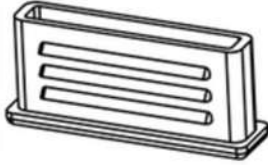
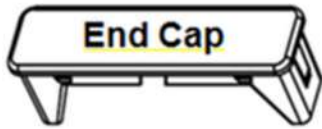



Product Description	Product Image	Item Code	Product Size	Colour / Material
65x16x1.2 Angle Bracket (LH & RH Needed)		AMI-6515LVR	65 x 16 x 1.2mm To Suit AMI-1603	Black Plastic
				Pearl White Plastic
Fence U Channel Top/Bottom Cover		AMI-PLCAP	26 x 30 To Suit AMI-129 (Fencing Channel)	Black Plastic
Slat Support Top/Bottom Cover		AMI-SLATSUPP-CAP	25 x 11.5 To Suit AMI-163 (Slat Support)	Black Plastic
Fence 135d U Channel Top/Bottom Cover		AMI-135DG	55 x 30 To Suit AMI-175 (135d Channel)	Black Plastic
Operable 88mm Louvre Blade Clip		AMI-88mm-Lclip-B	88mm To Suit AMI-227 (88mm Louvre Blade)	Black Plastic
		AMI-88mm-Lclip-W	88mm To Suit AMI-227 (88mm Louvre Blade)	Pearl White Plastic
Plastic End Cap		AMIPL - 502D	50 x 50 x 2 Dome	Black Plastic
		AMIPL - 503	50 x 50 x 2 & 3mm	
		AMIPL - 653	65 x 65 x 3	
		AMIPL - 100503	100 x 50 x 3	
		AMIPL - 10103	100 x 100 x 3	
		AMIPL - 15503	150 x 50 x 3	
Slat Plastic Endcap		AMI-38-ENDCAP	38 x 16 x 1.2mm To Suit AMI-1601	Black Plastic / Colours
		AMI-65ENDCAP	65 x 16 x 1.2mm To Suit AMI-1603	
		AMI-100ENDCAP	100 x 16 x 1.2mm To Suit AMI-012	
Aluminium Casting End Cap		AMI1665CAST	65 x 16 x 1.2mm To Suit AMI-1603	MF Aluminium Casting
		AMI16100CAST	100 x 16 x 1.2mm To Suit AMI-012	
		AMI - 76.2CAST	76.2 x 25.4 x 2.4mm To Suit AMI-1181	

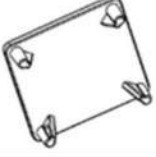
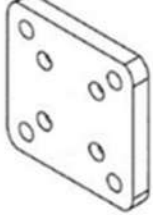
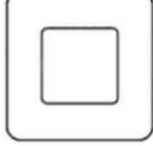
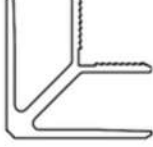
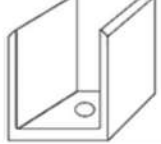

Product Description	Product Image	Item Code	Product Size	Colour / Material
Aluminium Spear "Fleur De Lis" Female		AMI-F-MB19	102mm To Suit AMI-1270 (19mm Round Tube)	MF Aluminium Casting
Aluminium Picket "Sovereign" Male		AMI-SOVEREIGN	72mm To Suit AMI-1603 (65x16x12mm RHS)	MF Aluminium Casting
Aluminium Spear "Centinel" Female		AMI-M-OB16	148mm To Suit AMI-1267 (16mm Round Tube)	MF Aluminium Casting
		AMI-M-OB19	148mm To Suit AMI-1270 (19mm Round Tube)	
Single Lug Bracket		AMI-FB30P	30x30 To Suit AMI-2784 (30x30mm SHS)	MF Aluminium Casting
		AMI-FB38P	38x25 To Suit AMI-2883 (38x25mm SHS)	
		AMI-FB40P	40x40 To Suit AMI-1238 (40x40mm SHS)	
50x50mm End Cap		AMI-FAB1002	50 x 50mm To Suit AMI-8861 (50x50 Screw Flute Post)	MF Aluminium Casting
				Powdercoated Aluminium
100x100mm Base Plate		AMI-FAB1001	100 x 100mm To Suit AMI-8861 / AMI-162 (50x50 Screw Flute Post)	MF Aluminium
				Powdercoated Aluminium
				Timber Grain
100x100mm Dress Ring		AMI-FAB1003	100 x 100 To Suit AMI-162 (50x50 Post)	Mill Finish Aluminium
Gate Frame Corner Stake		AMI-9584	90x90 To Suit AMI-1238 (Gate Frame corner )	MF Aluminium
Concealed Channel Fixing Bracket		AMI-9519	50x50 To Suit AMI-1242 (50x50x2 SHS)	MF Aluminium



**All Metal Industries**

**Gate Hardware  
Stocked Products**

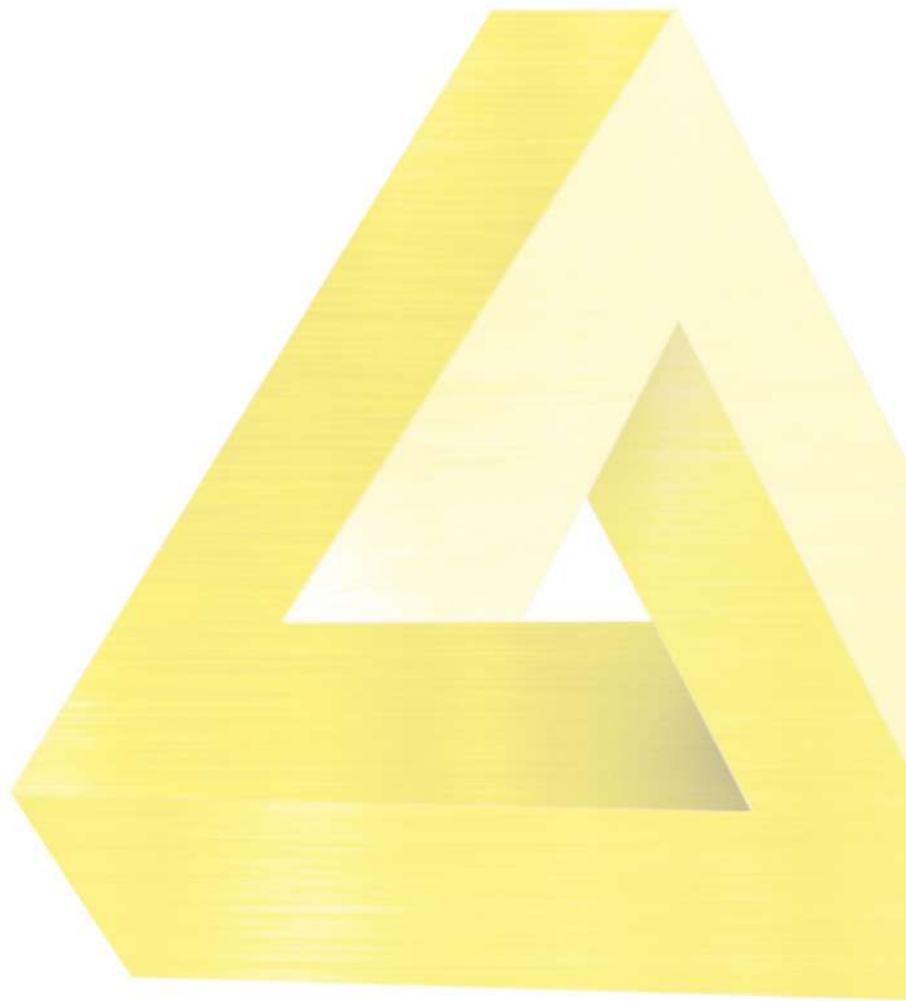



Product Description	Product Image	Item Code	Product Size	Colour / Material
Sliding Gate Nylon Block		AMI-S-NBLOCK	76 x 74 x 62mm To Suit AMI-2567/AMI-2567	Black Plastic
				Pearl White Plastic
6 EYE Automatic Gate Gear Rack		AMI-Gate Gear Rack	1000mm	Black Nylon Coated Steel
Lokklatch Key Alike (Deluxe)		AMI-LATCH	Privacy and Security Gate Latch (Key'd Alike)	Black Plastic
Lokklatch Individual keys (Deluxe)		AMI-LATCH KEYD ALIKE	Privacy and Security Gate Latch	Black Plastic
D&D Kwikfit Self Closing Hinge With Legs		AMI-KWIKFIT	To suit self-closes gates up 20kg	Black Plastic
D&D TRUCLOSE Heavy Duty Hinge NO LEGS		AMI-GATE-HD	To suit self-closes gates up 30kg	Black Plastic
D&D TRUCLOSE Regular Hinge NO LEGS		AMI-GATE-RD	To suit self-closes gates up 70kg	Black Plastic



**All Metal Industries**

**Gate Automation  
Stocked Products**

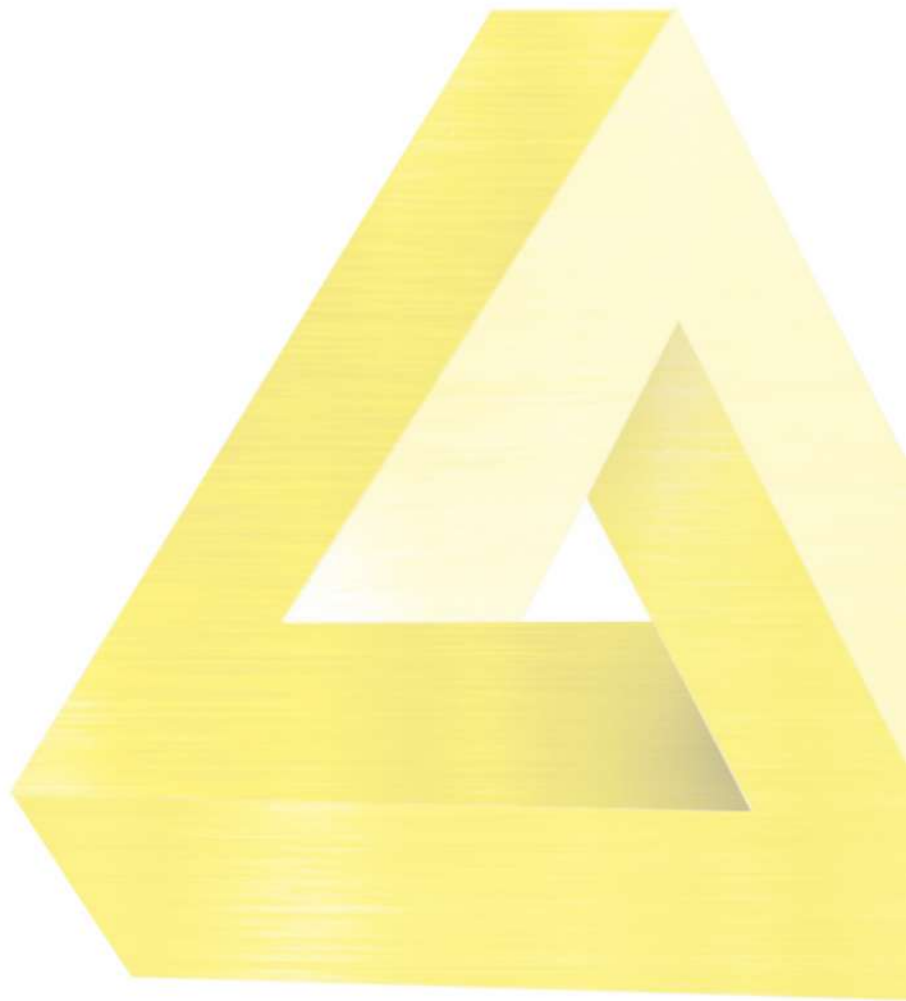



Product Description	Product Image	Item Code	Product Kit Inclusions
<b>CENTSYS D5-EVO (500KG) Kit - Domestic And Light Industrial Applications</b>		AMI-D5 EVO KIT	D5-EVO 500KG 240V INPUT (12V DC System) PCB, 1.8A SM Charger, Multichannel Nova Receiver, 2 X Four button transmitters, Chronoguard Timer. Includes Battery and Rack
<b>CENTSYS D10 (1000KG) Kits - Commercial And Industrial Application</b>		AMI-D10 EVO KIT	D10 1000KG Commercial Operator 240V Input (24V DC System) PCB, Charger, Multichannel Nova Receiver, Chronoguard Timer. Includes Remotes, Batteries and Rack.
<b>CENTSYS Vantage 400 Operator (SINGLE) KIT</b>		AMI-V400SINGLE	Vantage 400 - 12V DC Linear Operator With Pistondrive- Stroke 500MM, 240V Input (Standard) V-Series Wallbox Including: Controller, Multichannel Receiver, 2 X Four Button Transmitters, 1.8A SM Charger, Mains Isolater, Battery 12V, 7.2AH- Sealed Maintenance Free
<b>CENTSYS Vantage 400 Operator (DOUBLE) KIT</b>		AMI-V400DOUBLE	Vantage 400 - 12V DC Linear Operator With Pistondrive- Stroke 500MM, 240V Input (Standard) V-Series Wallbox Including: Controller, Multichannel Receiver, 2 X Four Button Transmitters, 1.8A SM Charger, Mains Isolater, Battery 12V, 7.2AH- Sealed Maintenance Free
<b>CENTSYS Vantage 500 Operator (SINGLE) KIT</b>		AMI-V500SINGLE	Vantage 500 - 12V DC Linear Operator With Pistondrive- Stroke 500MM, 240V Input (Standard) V-Series Wallbox Including: Controller, Multichannel Receiver, 2 X Four Button Transmitters, 1.8A SM Charger, Mains Isolater, Battery 12V, 7.2AH- Sealed Maintenance Free
<b>CENTSYS Vantage 500 Operator (DOUBLE) KIT</b>		AMI-V500DOUBLE	Vantage 500 - 12V DC Linear Operator With Pistondrive- Stroke 500MM, 240V Input (Standard) V-Series Wallbox Including: Controller, Multichannel Receiver, 2 X Four Button Transmitters, 1.8A SM Charger, Mains Isolater, Battery 12V, 7.2AH- Sealed Maintenance Free





**All Metal Industries**

**Processing hardware**  
**Stocked Products**

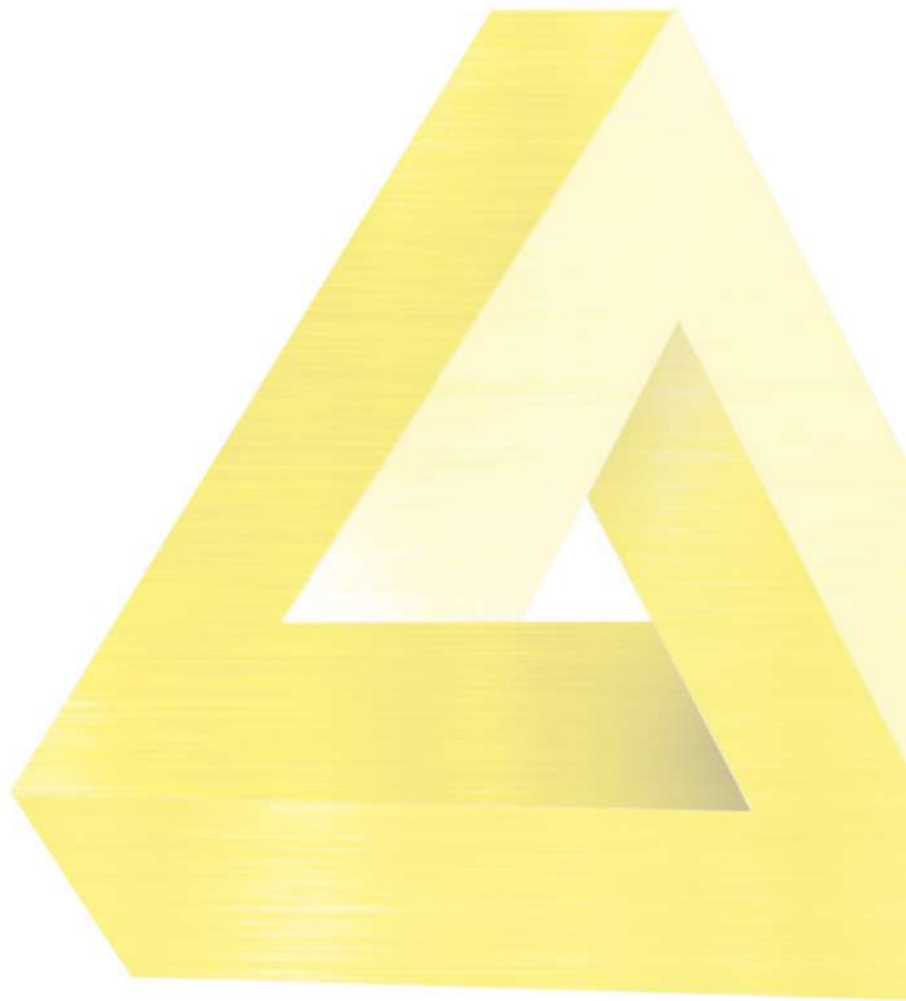



Product Description	Product Image	Item Code	Product Size	Colour / Material
Aluminium Saw Blade		AMI-Saw255	255mm (80T)	Tungsten Carbide
Aluminium Saw Blade		AMI-Saw305	305mm (96T)	Tungsten Carbide
Aluminium Saw Blade		AMI-Saw355	355mm (120T)	Tungsten Carbide
Aluminium Up-Spiral CNC Piece		AMI-CNC6126	6mm x 12mm x 6mm	Tungsten Carbide
Aluminium Up-Spiral CNC Piece		AMI-CNC6256	6mm x 25mm x 6mm	Tungsten Carbide



**All Metal Industries**

**Timber Colour Range**  
**Stocked Products**

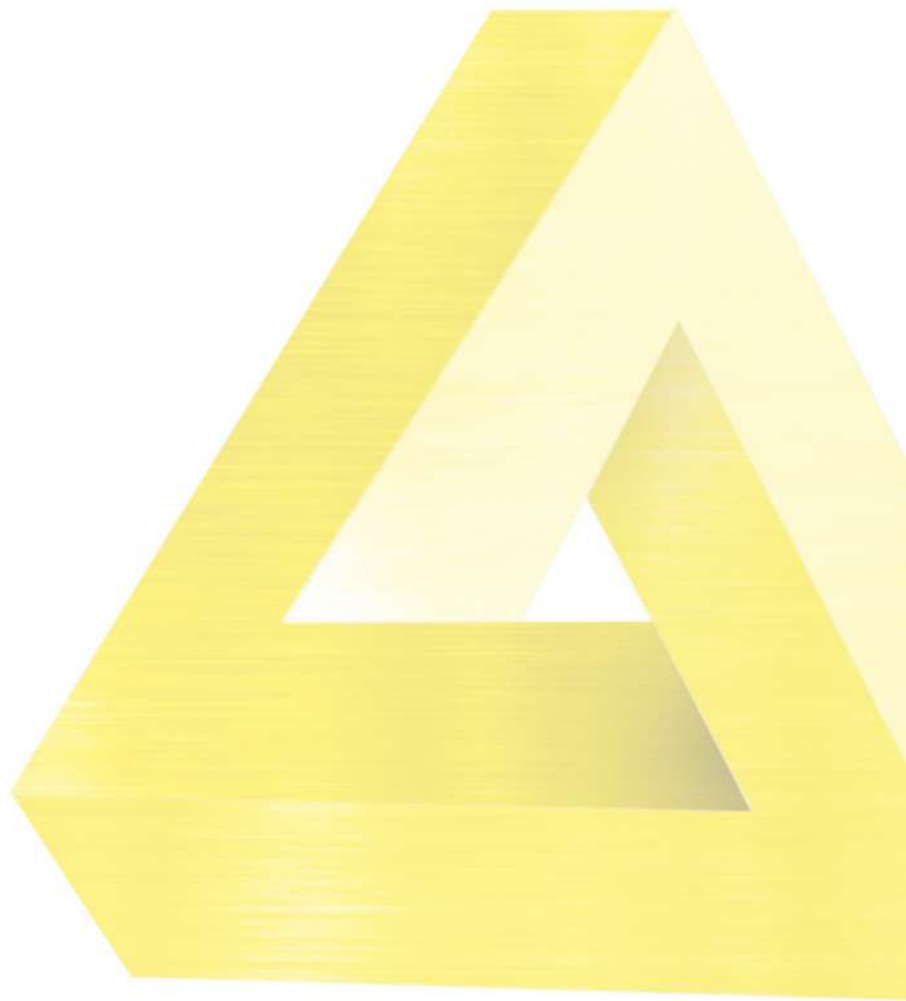



Beach oak



Wild Olive



Western Cedar



Jarrah



## DISCLAIMER

Whilst care was taken in the preparation of the data contained in this handbook, All Metal Industries accepts no liability for the accuracy of information supplied and should be used as a guide only.

## TERMS & CONDITIONS OF SALE

A full copy of All Metal Industries Terms & Conditions of Sale document is available on request.

## PRODUCT WARRANTY

All Metal Industries warrants the quality of our products. Warranty liability extends to the value of the product supplied or the replacement of only, at All Metal Industries option. All Metal Industries does not accept any claim for consequential loss.

Date : OCTOBER 2023





## **TALK TO US**

 **(08) 6455 0200**

 ***Sales@allmetalindustries.com.au***

 ***11 Yelland Way, Bassendean, Western Australia 6054***