



All Metal Industries

Aluminium Products Catalogue

Stocked Products

2023

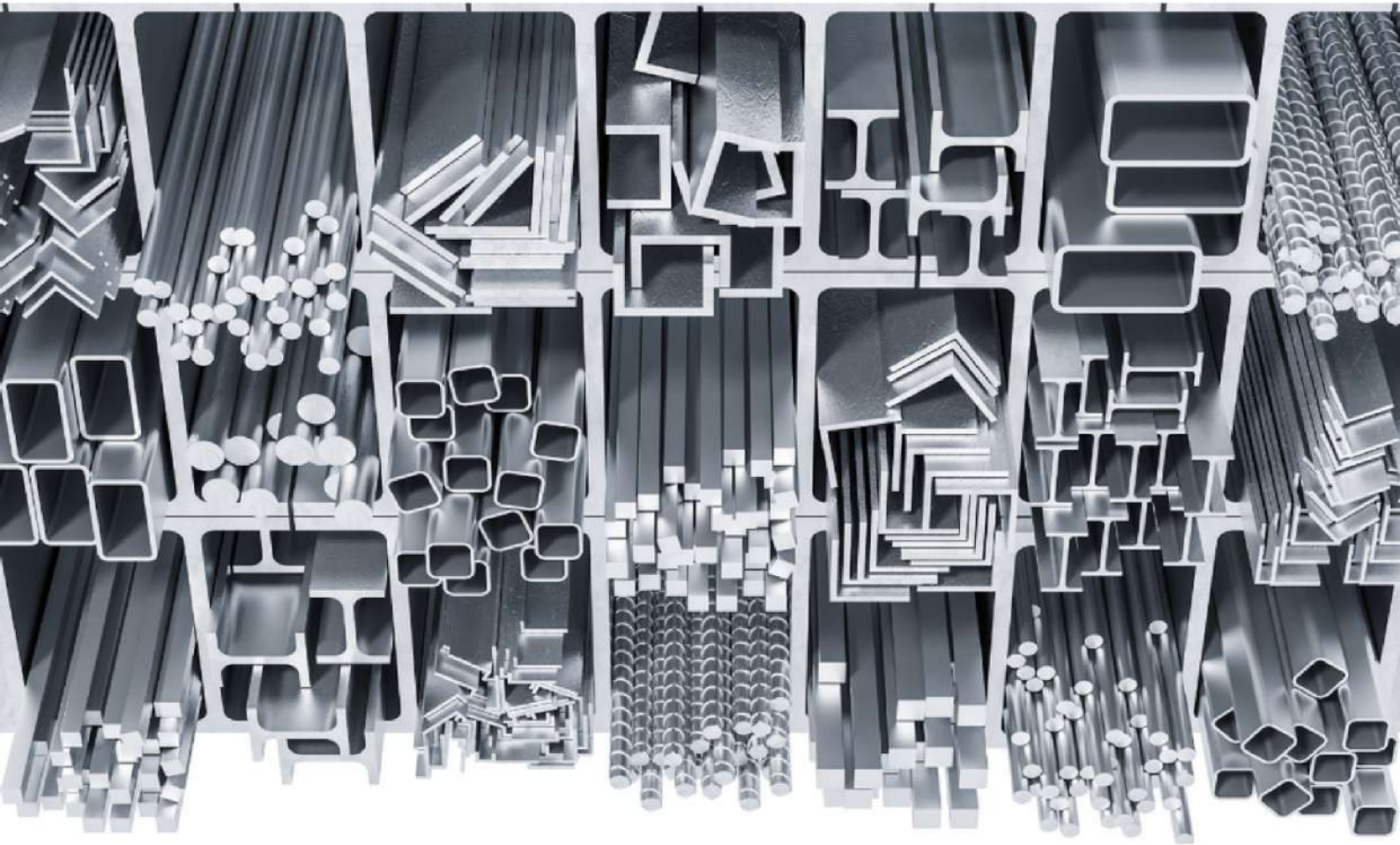

Company Introduction



All Metal Industries

All Metal Industries is Western Australia's premier metal distribution company, with a reputation for reliable supply, strong stock levels and supporting businesses of all sizes with supply of aluminium extrusions, castings, stainless steel mesh and specialist steel products.

Locally owned and operated, our primary focus is on developing strong customer relationships and supply agreements, allowing us to provide high quality and cost-effective supply of materials to a vast range of industries and markets across Australia. Our unwavering commitment to being the best at what we do has allowed us to establish ourselves as a leading stockholder of aluminium and metal distributor in Western Australia.

With the ongoing volatility of the market, we partner with our customers to understand their business and ensure our products and services remain relevant to their needs and provide them with a competitive advantage. Along with offering an extensive range of stocked solutions, we are also able to develop specific products, tailored to the individual needs of our customers and their project.

Primary industries we support:

- Engineering & Fabrication
- Fencing
- Building & Façade
- Transport
- Resource & Construction

With integrity and innovation at the foundation of our operations, All Metal Industries are committed to the reliable provision of products tailored to the needs of your business. Through continuous improvement and investment, All Metal Industries strives for excellence across service, pricing and quality of products, now and into the future.

Matthew Wimmer
Managing Director





| | |
|-------|--|
| 1-2 | Tech-1 Modular Sun Blade |
| 3-5 | Tech-2 Operable/Fixed 88mm Louvre Blade system |
| 6-8 | Tech-3 Mechanical Louvre System |
| 9-13 | Tech-4 Fencing Sections |
| 14-16 | Cool Room / Transportable Sections |
| 17-18 | Signage Sections |
| 19-22 | Geometric Sections |
| 23-25 | Castings, Endcaps and Brackets |
| 26-27 | Gate Hardware |
| 28-29 | Gate Automation |
| 30-31 | Processing Hardware |





All Metal Industries

Tech-1 Modular Sun-Blade System
Stocked Products

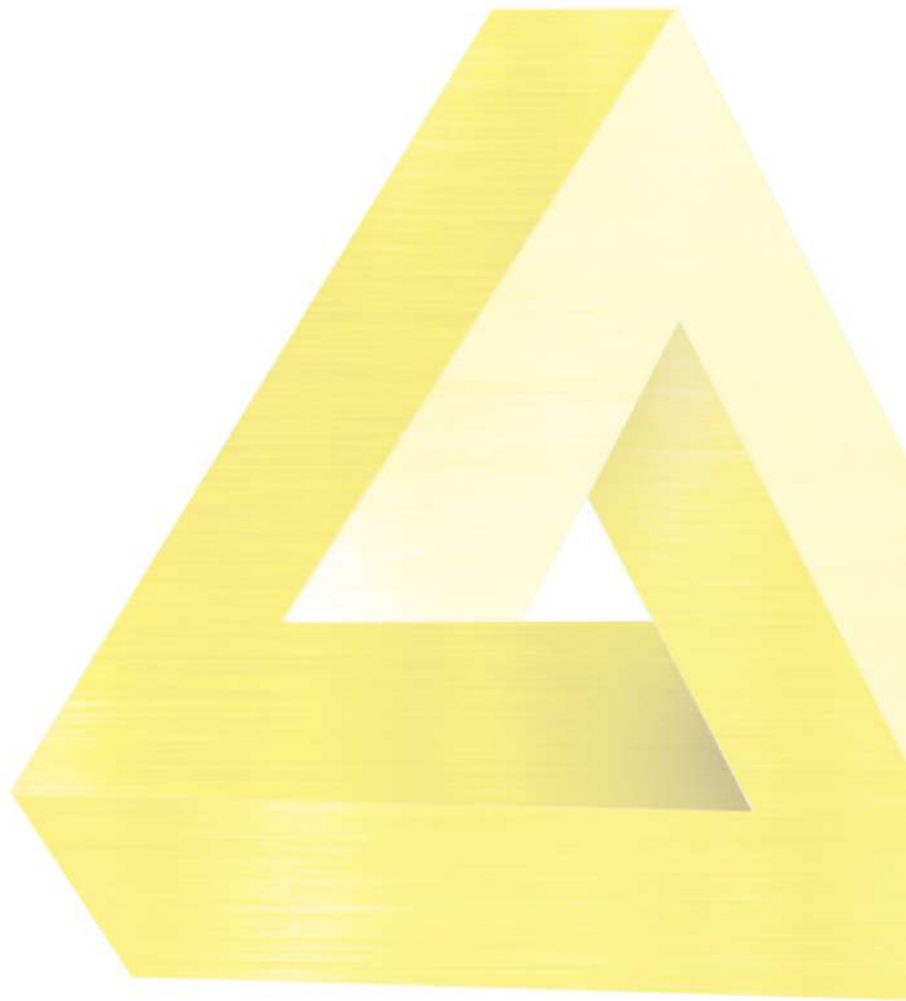

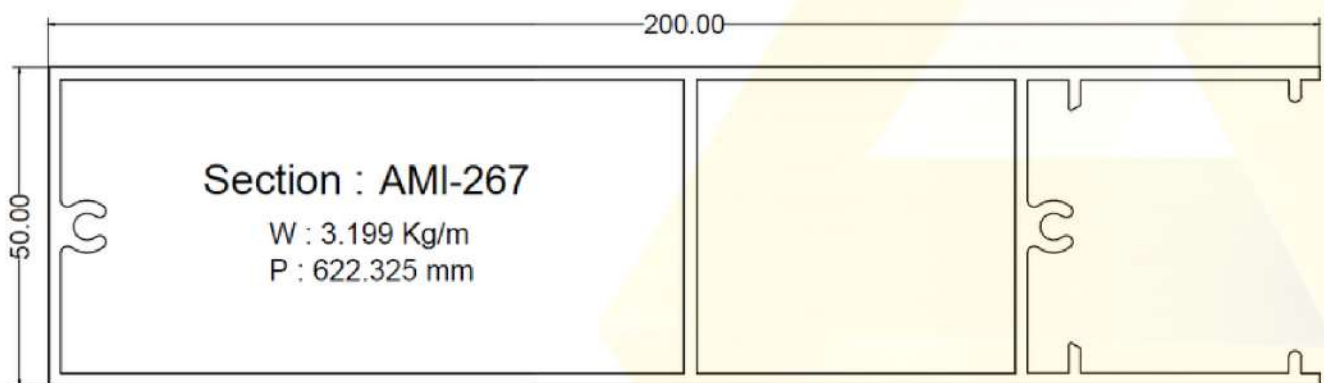
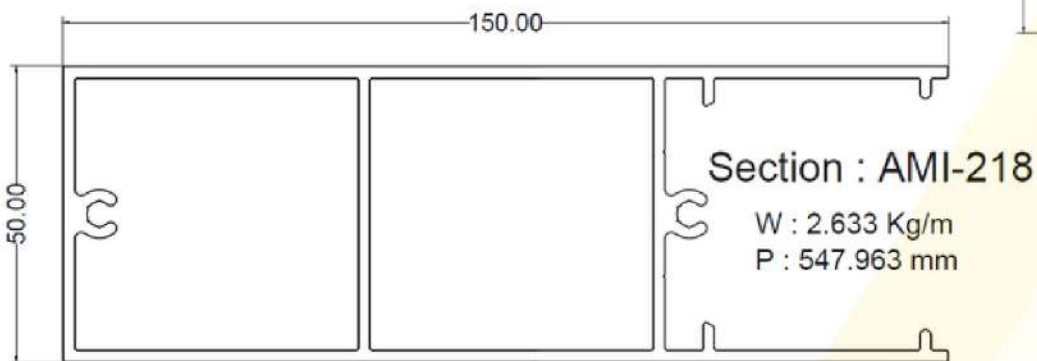
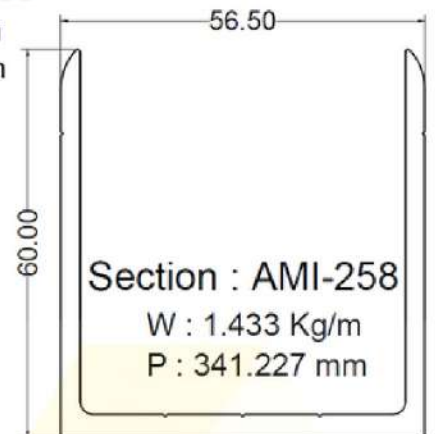
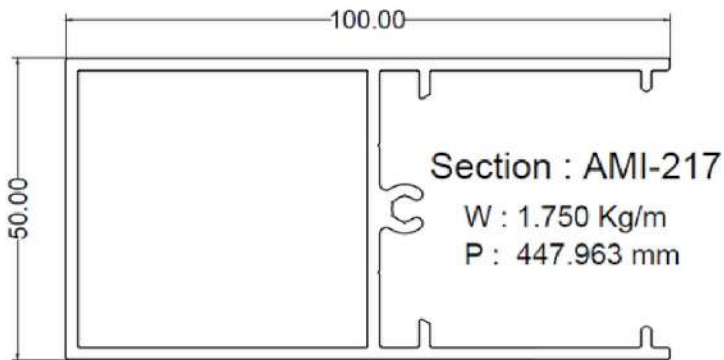
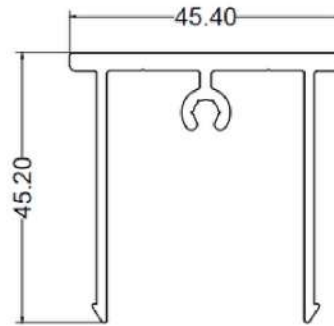
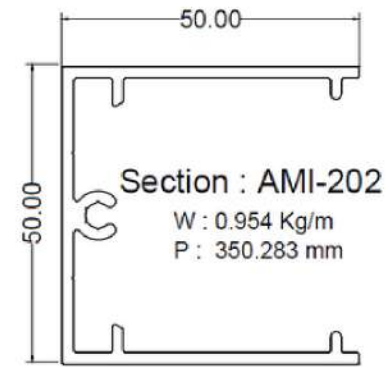



All Metal Industries

**Tech-2 Operable/Fixed 88mm Louvre System
Stocked Products**

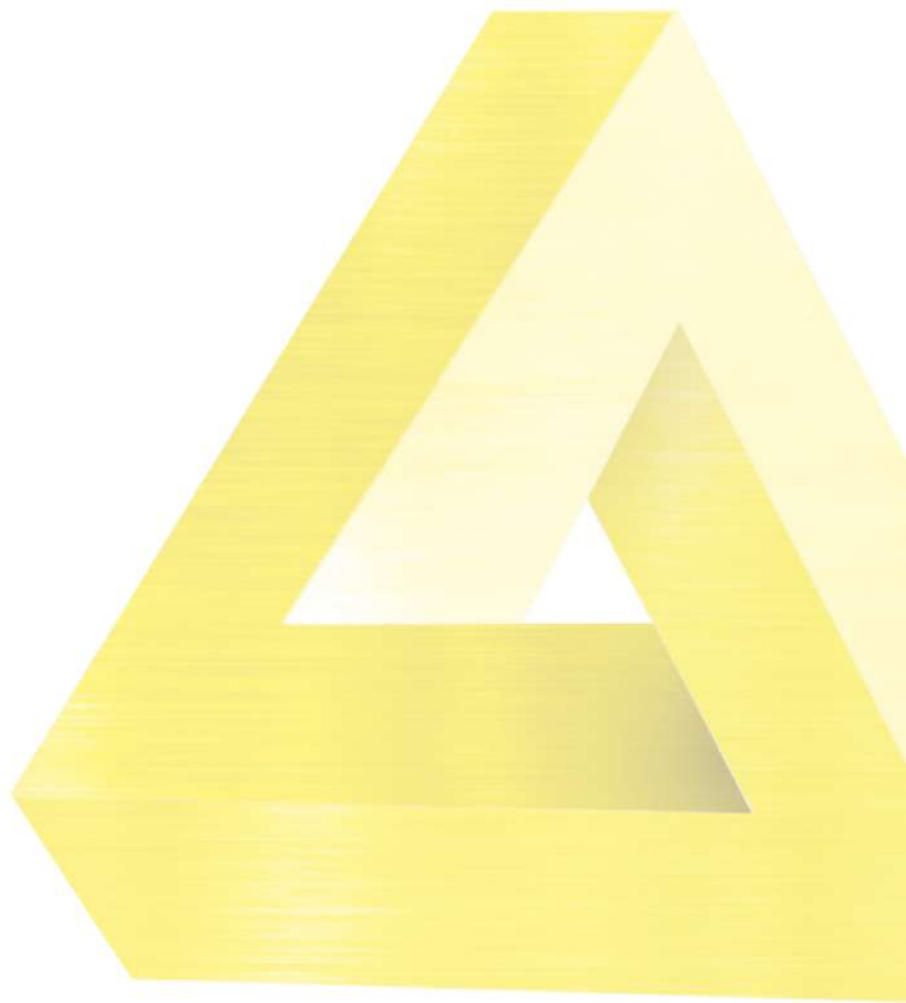

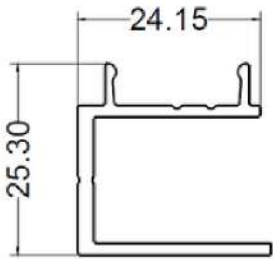

Section : AMI-129

W : 0.333 Kg/m
P : 155.94 mm

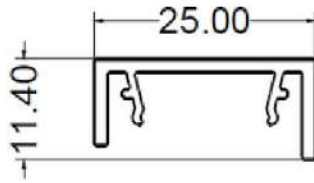

Section : AMI-130

W : 0.211 Kg/m
P : 114.80 mm

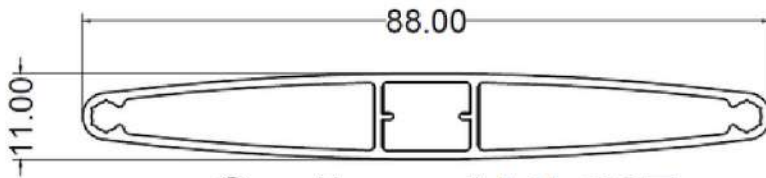

Section : AMI-227

W : 0.609 Kg/m
P : 183.26 mm

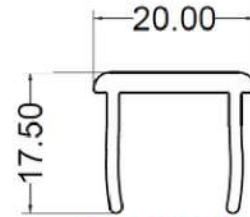

Pre-Punched

Section : AMI-233

W : 0.252 Kg/m
P : 101.35 mm

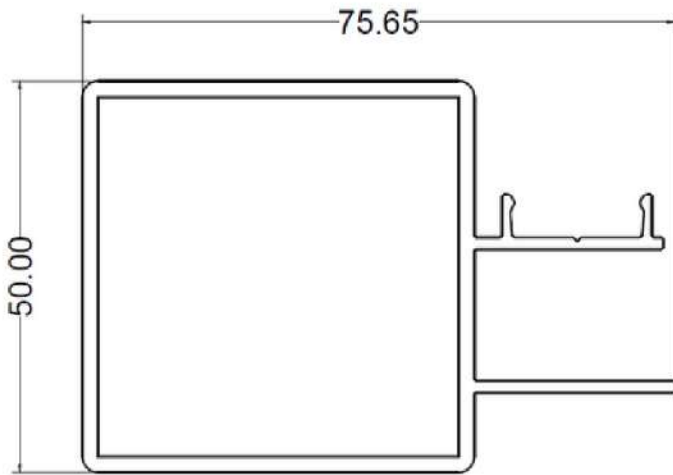

Section : AMI-135

W : 1.269 Kg/m
P : 316.60 mm

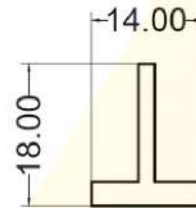

Pre-Punched
Louvre Handle

Section : AMI-251

W : 0.195 Kg/m
P : 64.00 mm

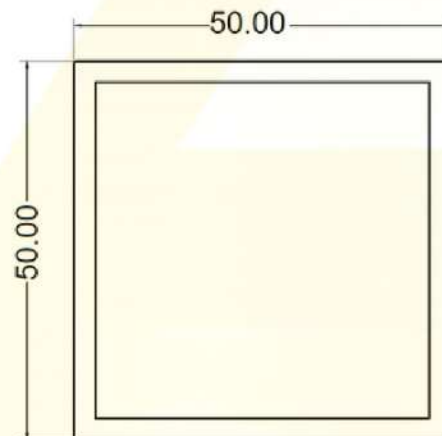

Pre-punched

Section : AMI-1243

W : 1.523 Kg/m
P : 200.00 mm



Single & Double Side Punched

Privacy

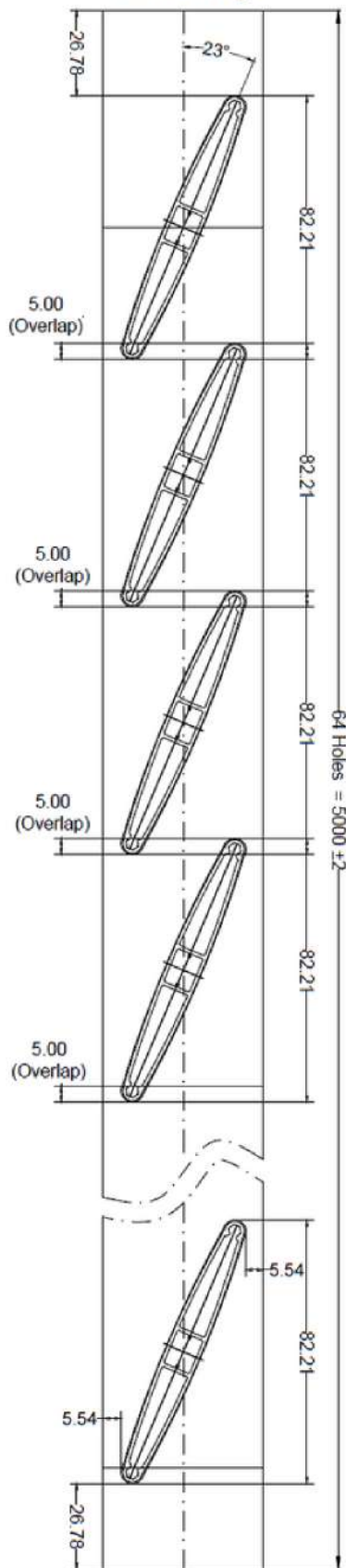

Non-Privacy

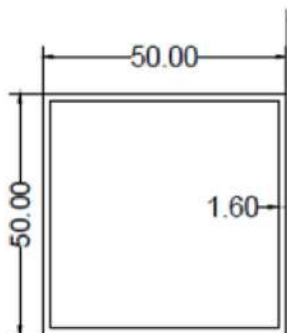
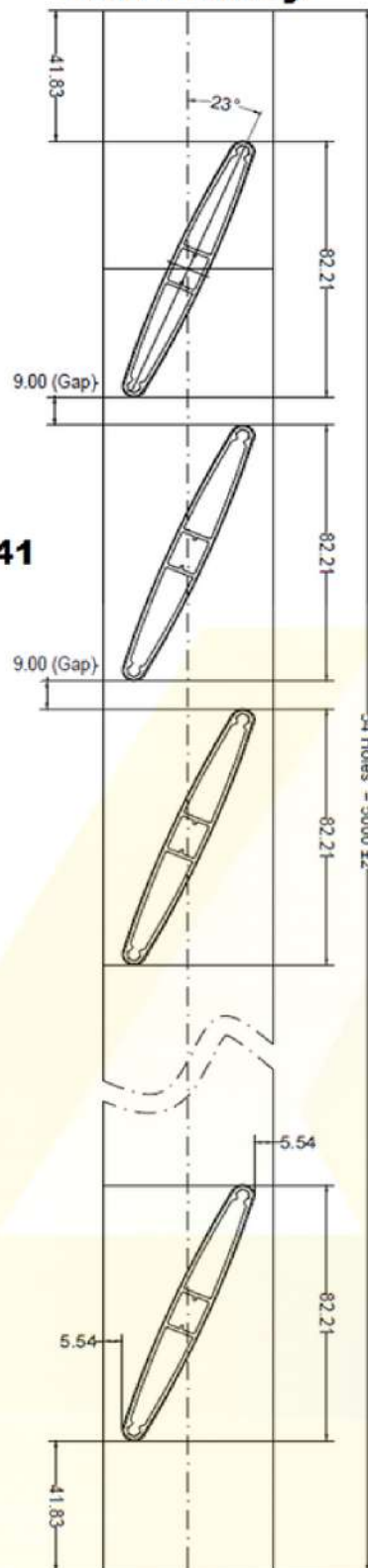

Section : AMI-1241

W : 0.837 Kg/m
P : 200 mm



All Metal Industries

Tech-3 Mechanical Louvre System
Stocked Products

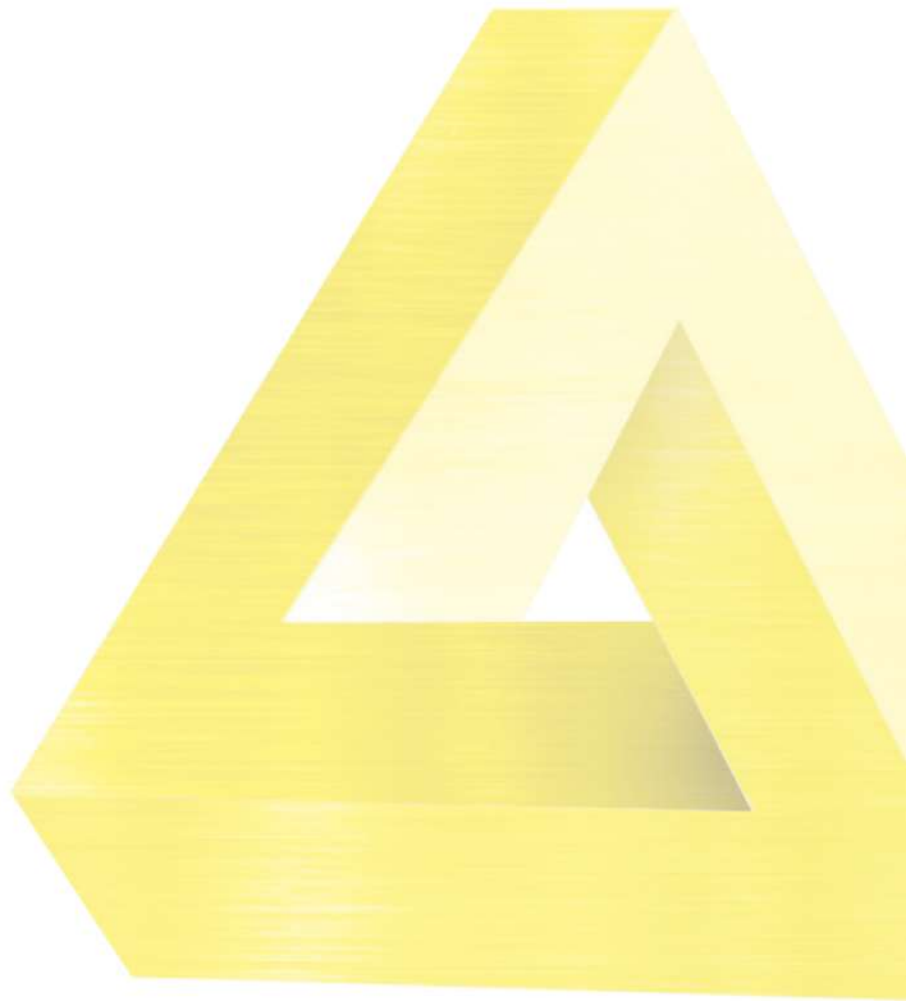

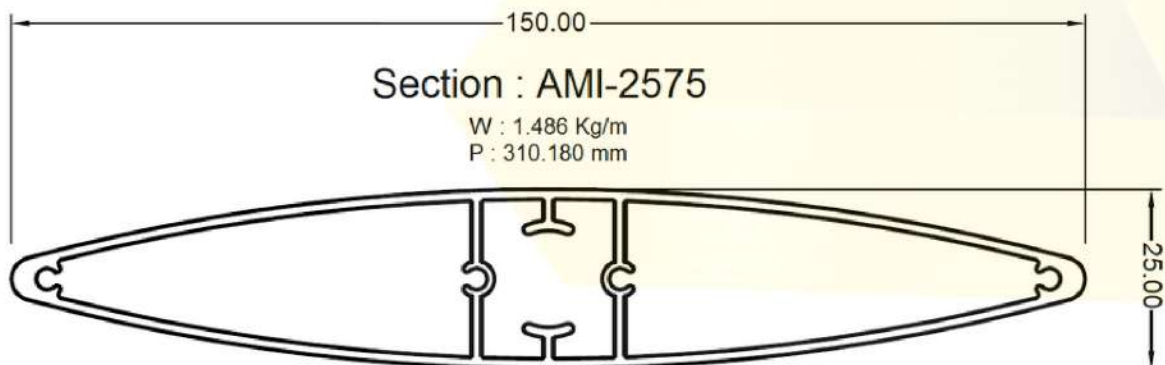
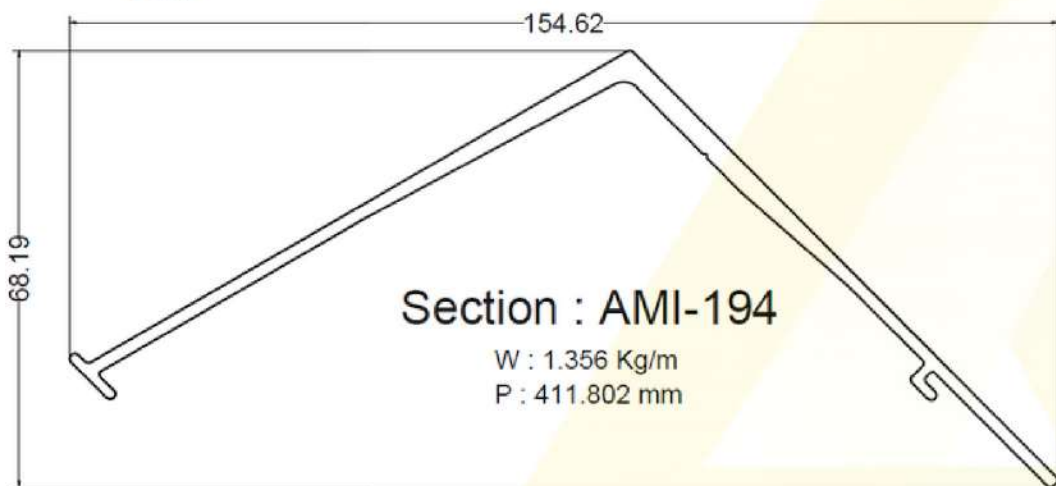
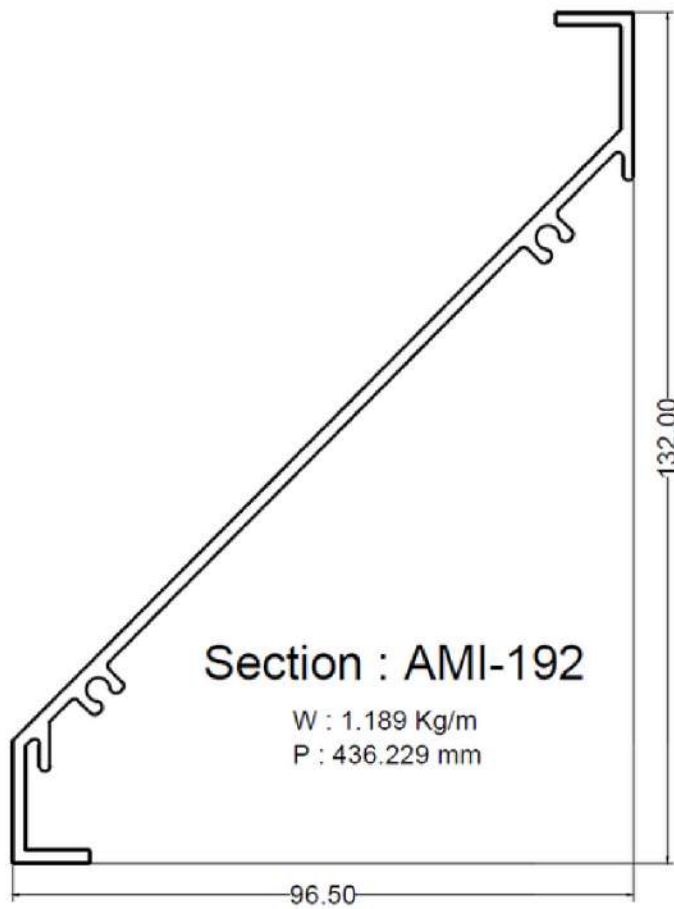

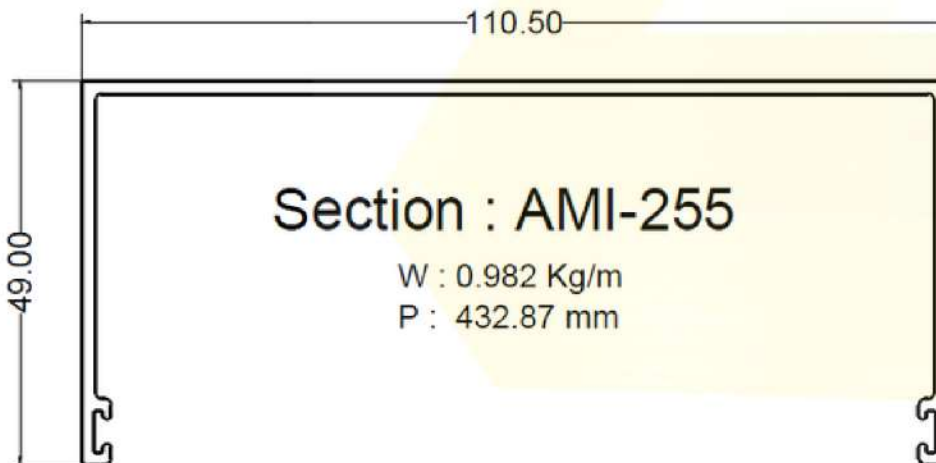
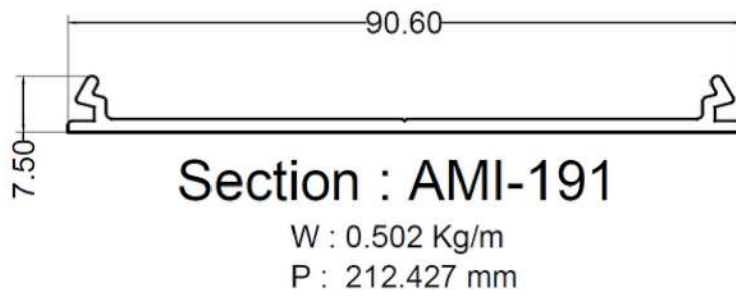
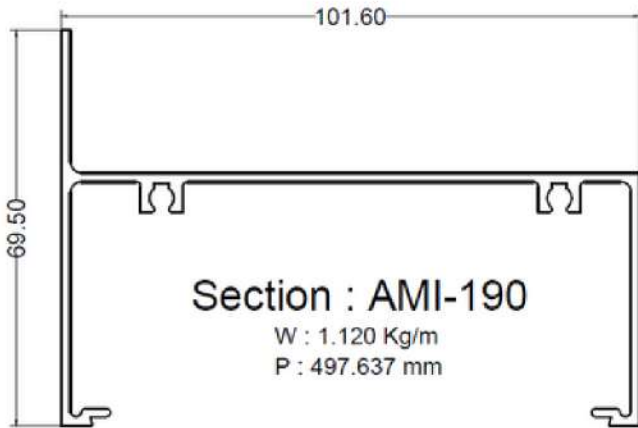



All Metal Industries

Tech-4 Fencing Sections
Stocked Products

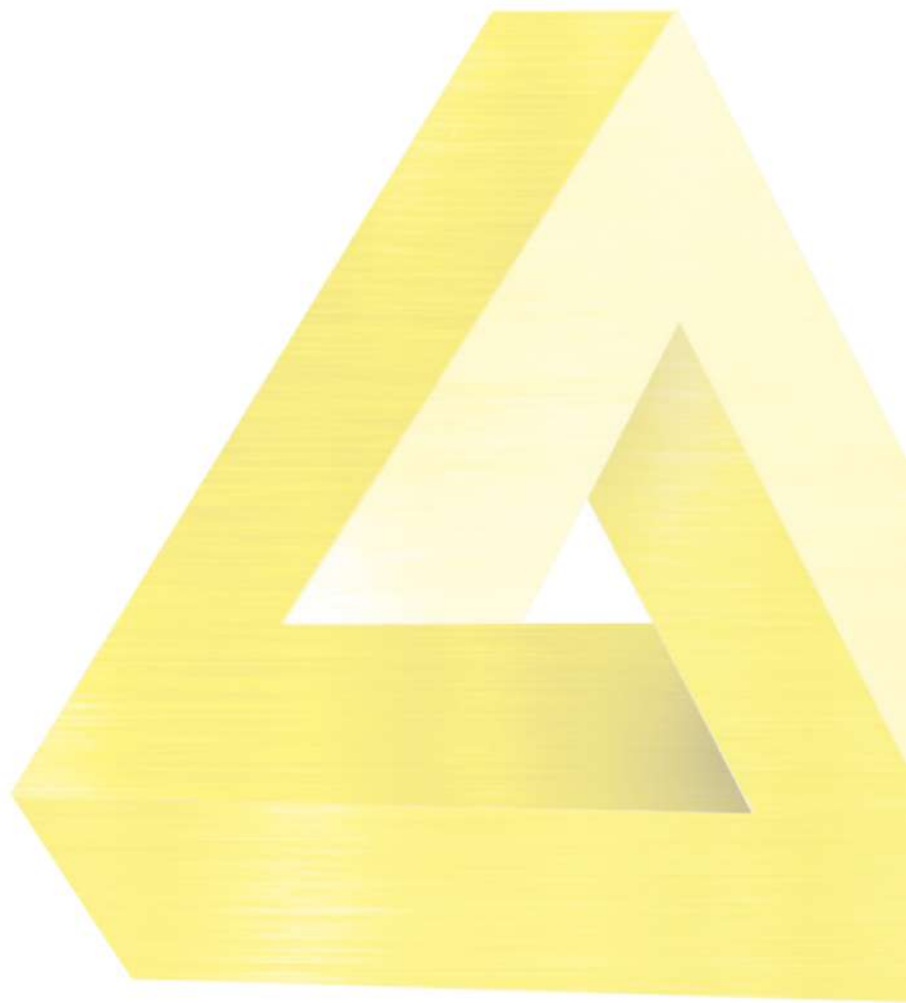

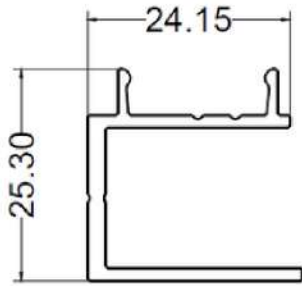

Section : AMI-129

W : 0.333 Kg/m
P : 155.94 mm

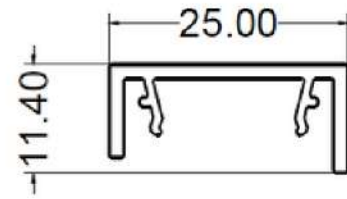

Section : AMI-130

W : 0.211 Kg/m
P : 114.80 mm

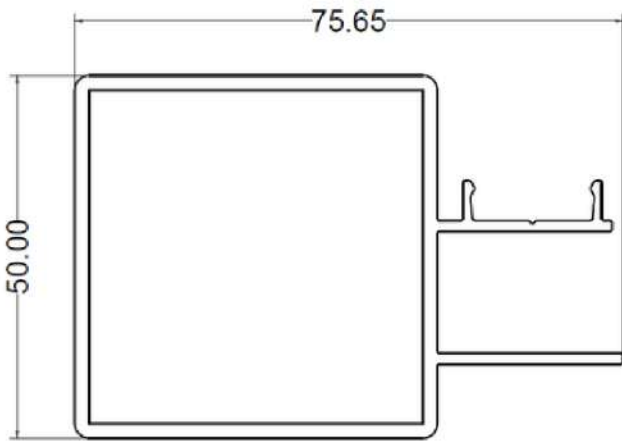

Section : AMI-134

W : 1.269 Kg/m
P : 316.60 mm

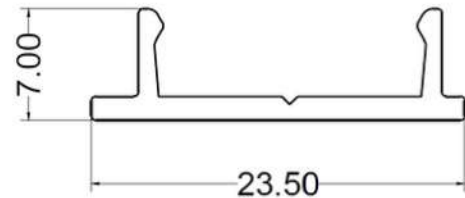

Section : AMI-163

W : 0.131 Kg/m
P : 71.209 mm

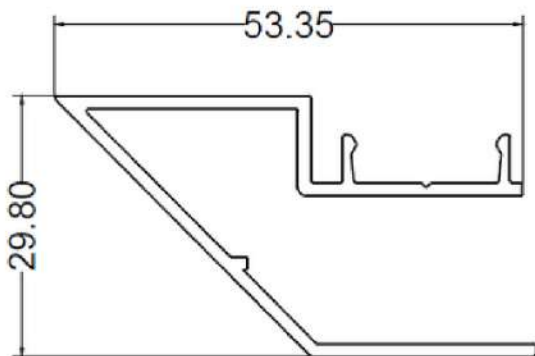

Section : AMI-175

W : 0.557 Kg/m
P : 277.70 mm

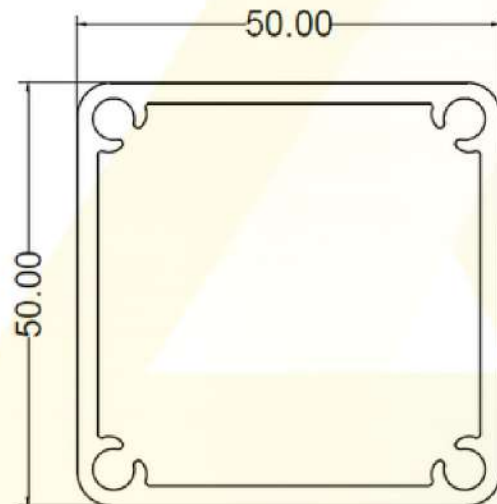

Section : AMI-162

W : 1.271 Kg/m
P : 193.133 mm

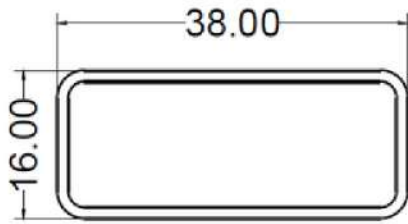

Section : AMI-1601

W : 0.322 Kg/m

P : 102.85 mm

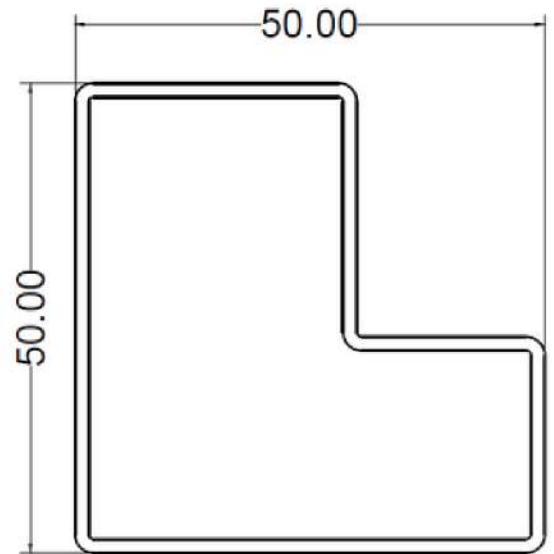

Section : AMI-121

W : 0.776 Kg/m

P : 195.50 mm

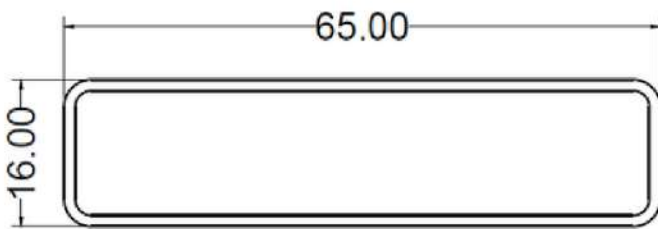

Section : AMI-1603

W : 0.496 Kg/m

P : 156.90 mm

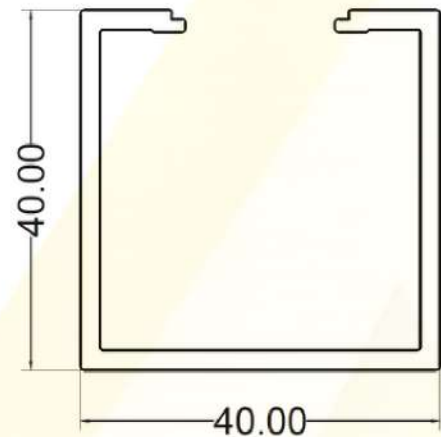

Section : AMI-261

W : 0.799 Kg/m

P : 271.928 mm

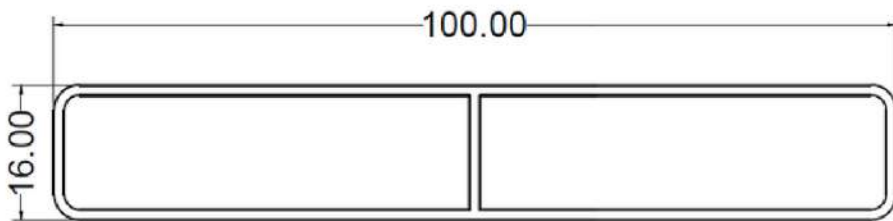

Section : AMI-012

W : 0.770 Kg/m

P : 226.85 mm

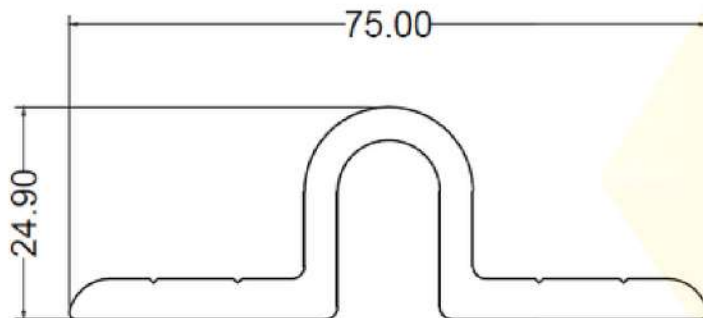

Section : AMI-243

W : 1.265 Kg/m

P : 222.48 mm

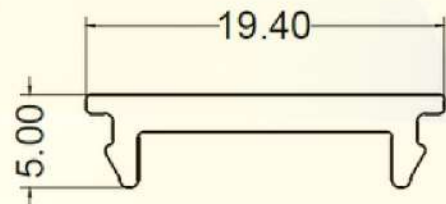

Section : AMI-262

W : 0.119 Kg/m

P : 53.045 mm

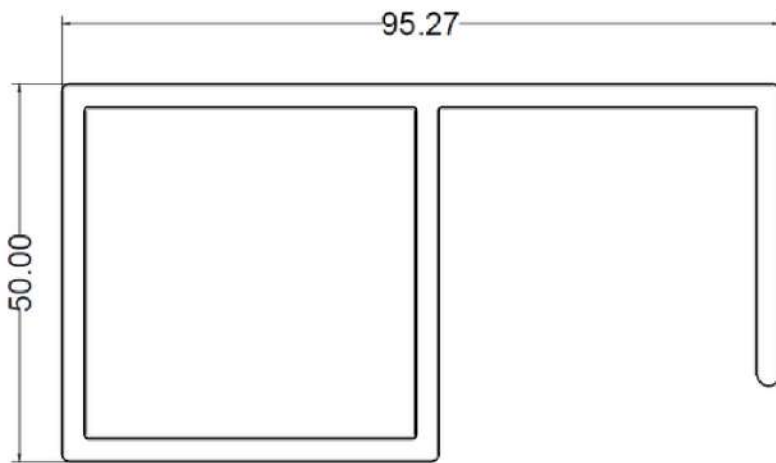

Section : AMI-2567

W : 2.193 Kg/m

P : 361.10 mm

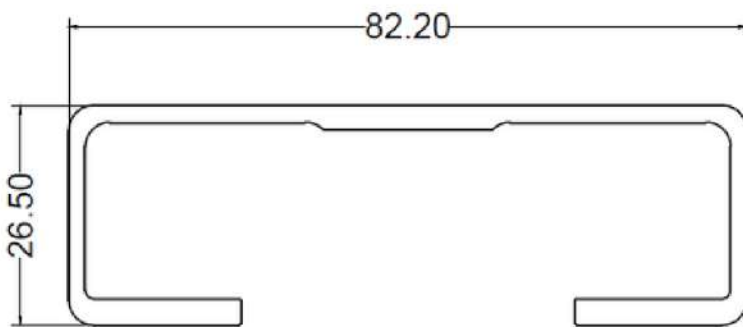

Section : AMI-241

W : 1.083 Kg/m

P : 333.40 mm

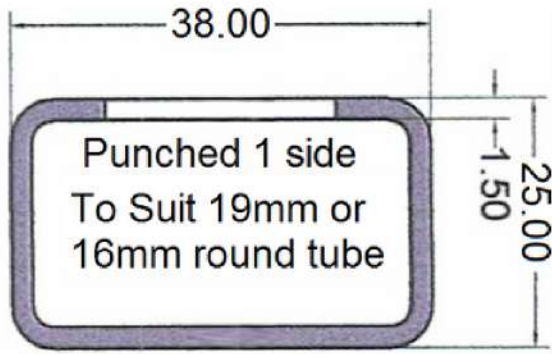

Section : AMI-2883

W : 0.473 Kg/m

P : 120.84 mm

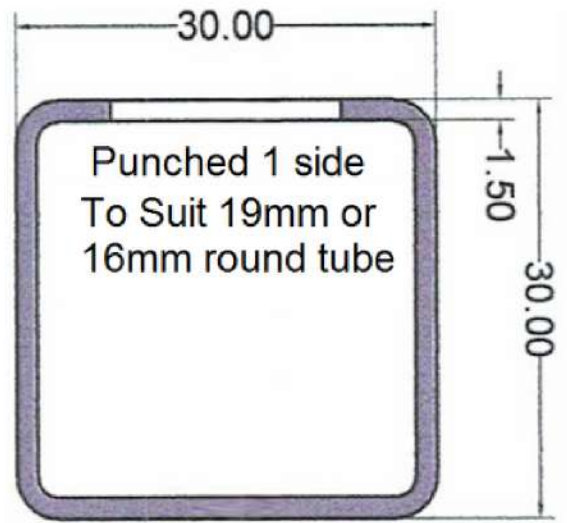
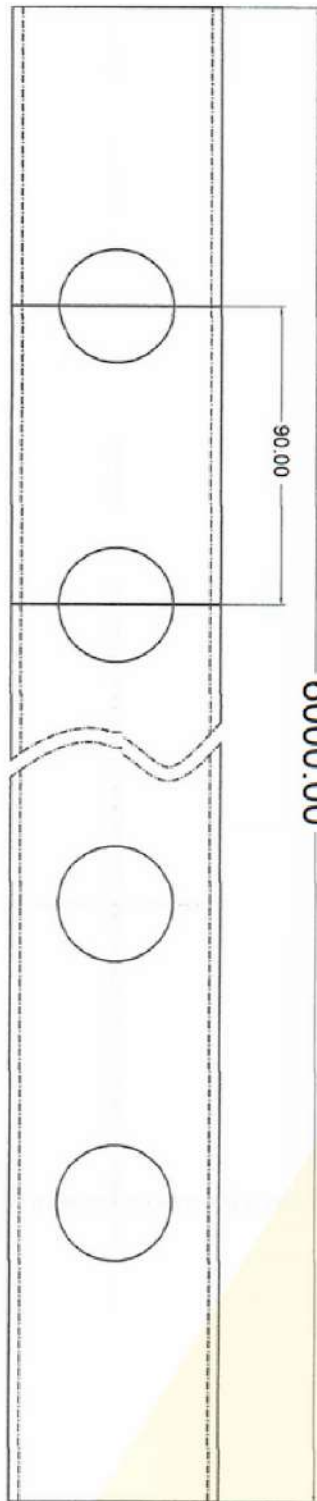
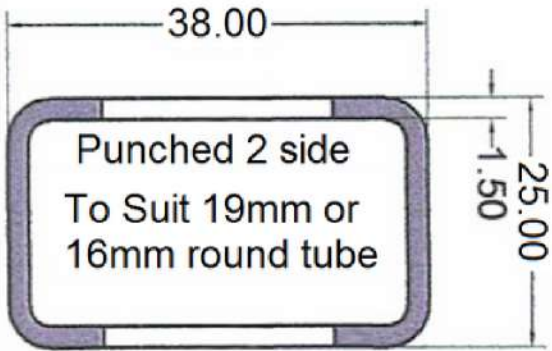

Section : AMI-2784

W : 0.448 Kg/m

P : 114.85 mm

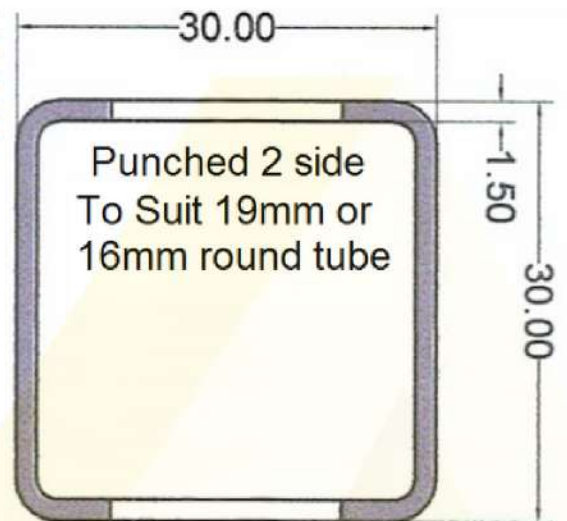



All Metal Industries

Coolroom / Transportable Sections
Stocked Products

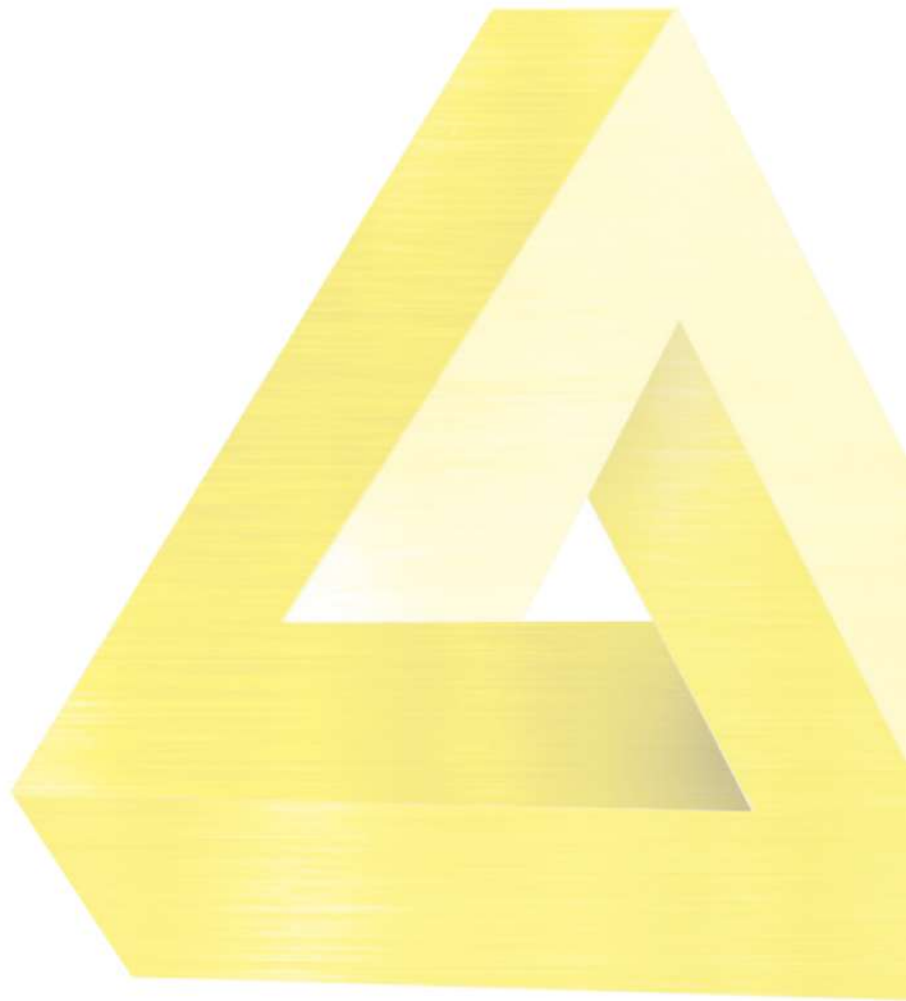

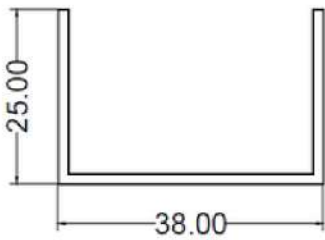

Section : AMI-002

W : 0.323 Kg/m
P : 173.20 mm

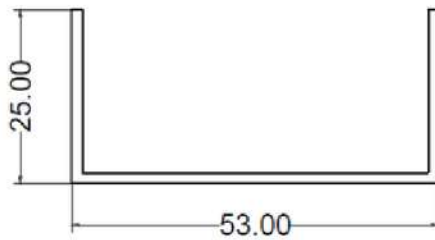

Section : AMI-004

W : 0.406 Kg/m
P : 203.00 mm

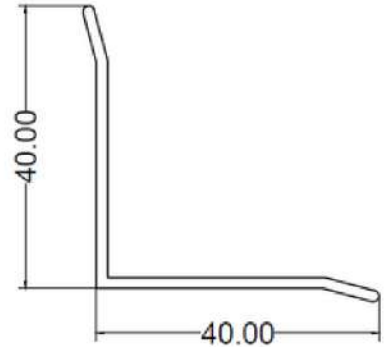

Section : AMI-001

W : 0.341 Kg/m
P : 159.628 mm

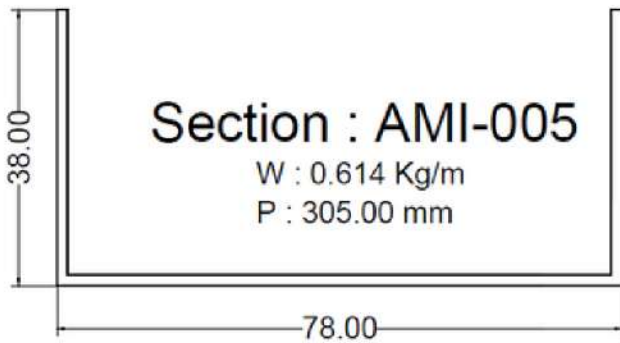

Section : AMI-005

W : 0.614 Kg/m
P : 305.00 mm

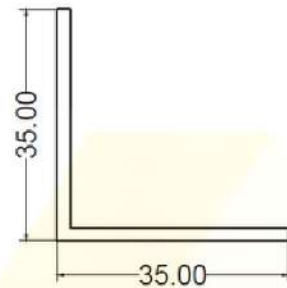

Section : AMI-036

W : 0.369 Kg/m
P : 140.00 mm

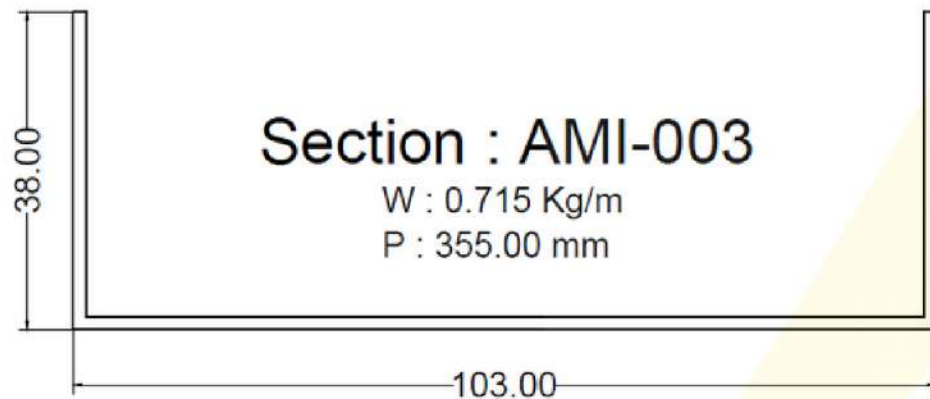

Section : AMI-003

W : 0.715 Kg/m
P : 355.00 mm

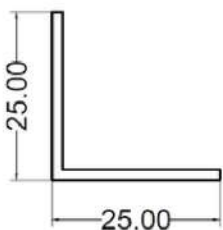

Section : AMI-1381

W : 0.210 Kg/m
P : 100.00 mm

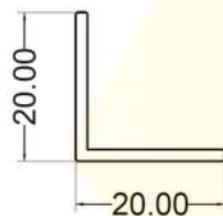

Section : AMI-1376

W : 0.166 Kg/m
P : 79.40 mm

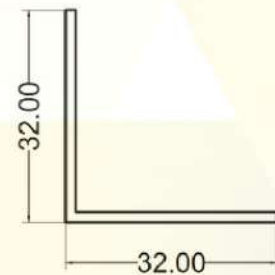

Section : AMI-1388

W : 0.271 Kg/m
P : 128.00 mm

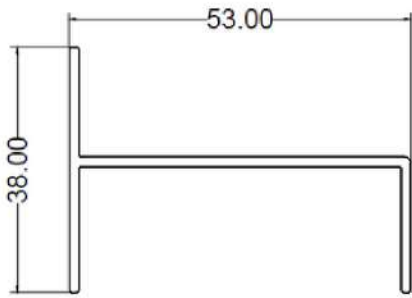

Section : AMI-046

W : 0.442 Kg/m
P : 219.15 mm

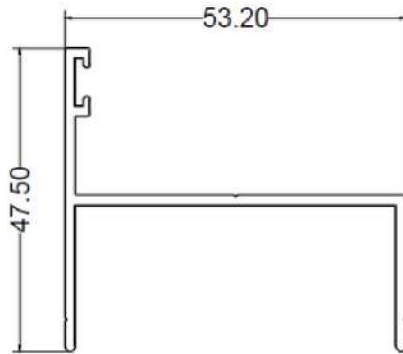

Section : AMI-082

W : 0.552 Kg/m
P : 260.269 mm

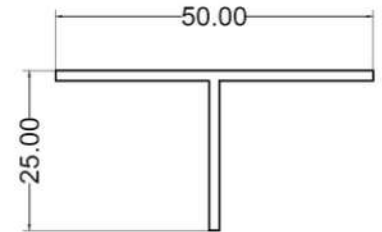

Section : AMI-1690

W : 0.318 Kg/m
P : 150.00 mm

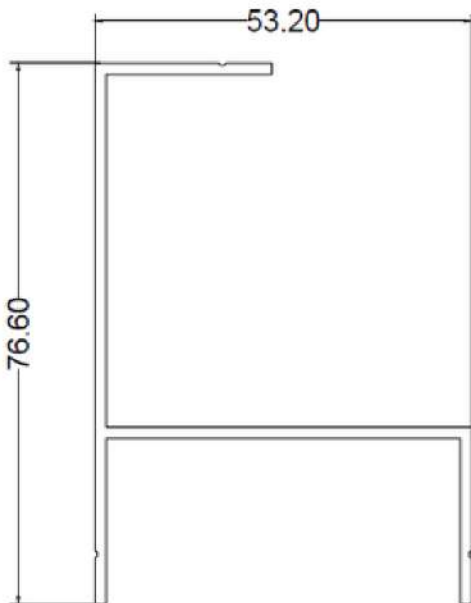

Section : AMI-080

W : 0.753 Kg/m
P : 352.00 mm

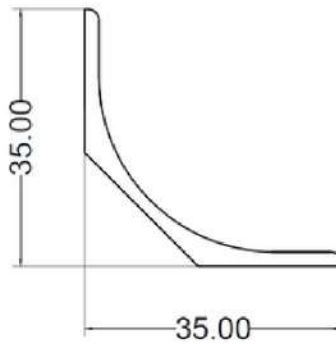

Section : AMI-260

W : 0.359 Kg/m
P : 119.366 mm

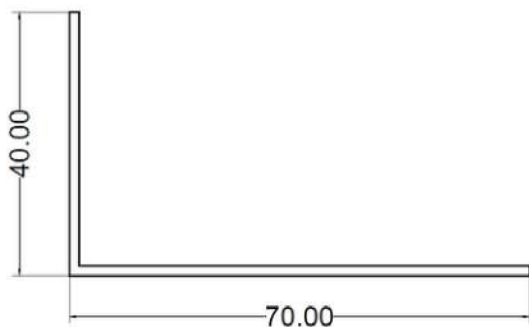

Section : AMI-1447

W : 0.441 Kg/m
P : 220.00 mm

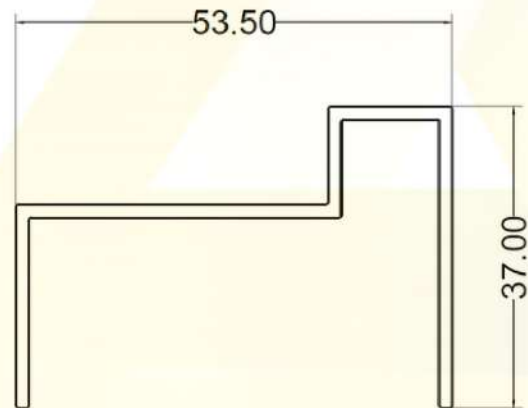

Section : AMI-048

W : 0.539 Kg/m
P : 250.26 mm



All Metal Industries

Signage Sections
Stocked Products

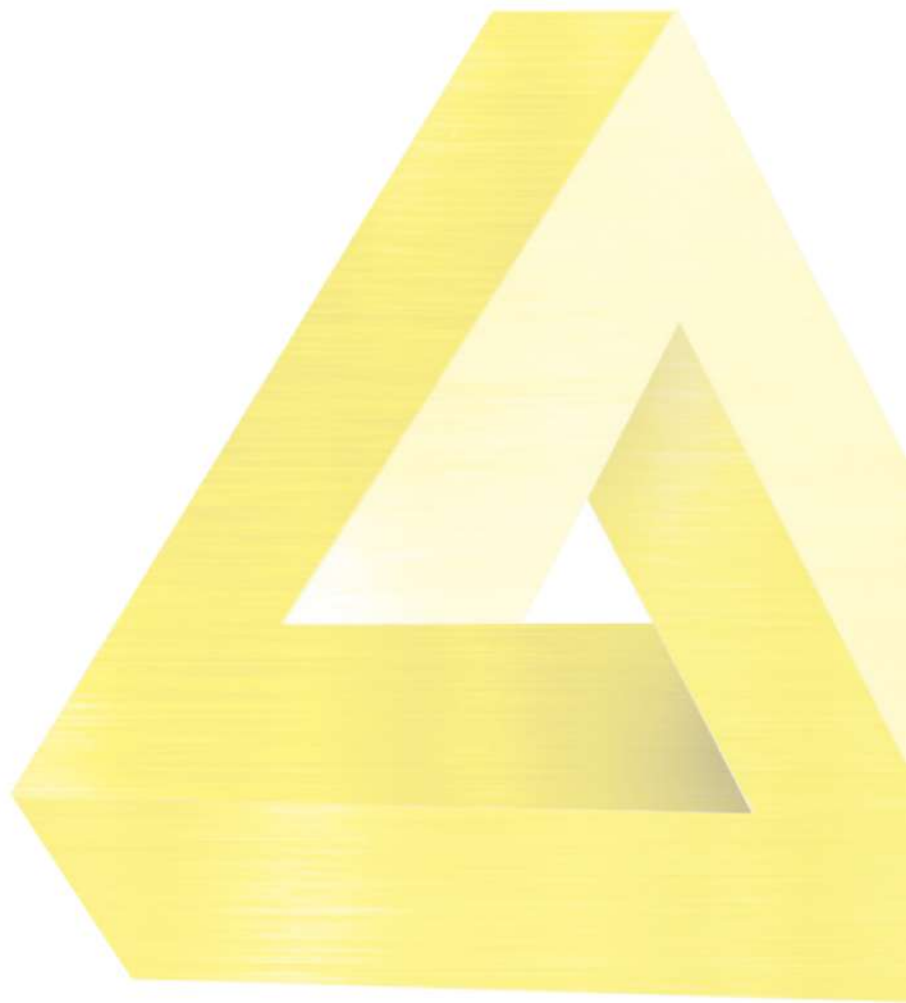

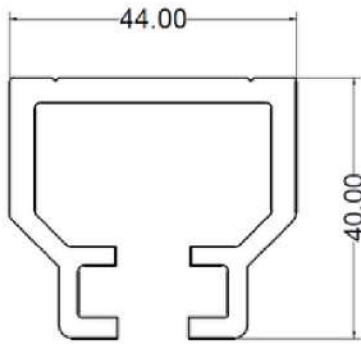

Section : AMI-211

W : 1.368 Kg/m
P : 295.347 mm

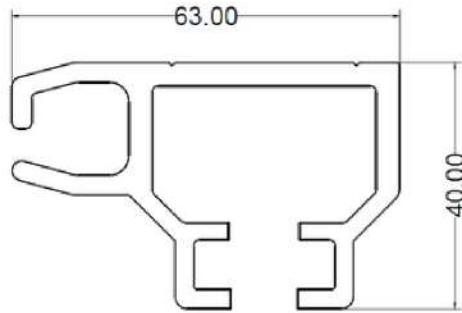

Available on request
Section : AMI-210

W : 1.756 Kg/m
P : 376.23 mm

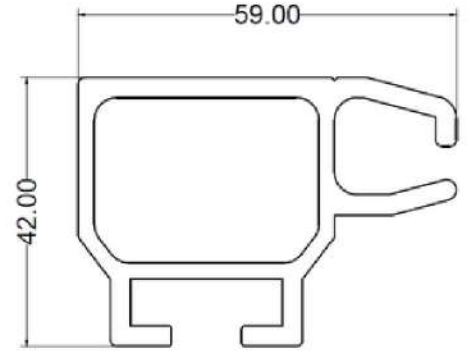

Available on request
Section : AMI-212

W : 1.612 Kg/m
P : 281.633 mm

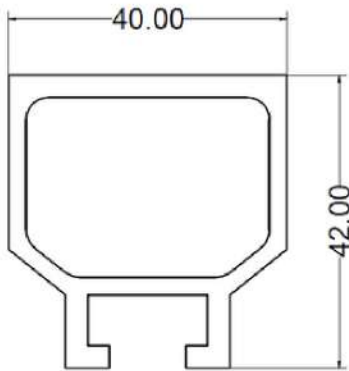

Available on request
Section : AMI-213

W : 1.237 Kg/m
P : 202.03 mm

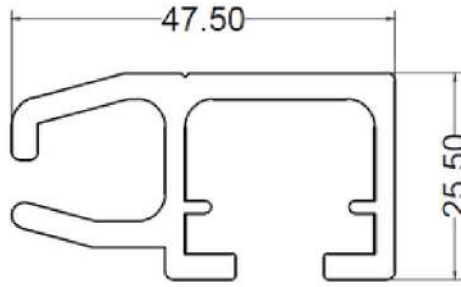

Available on request
Section : AMI-344

W : 1.072 Kg/m
P : 265.00 mm

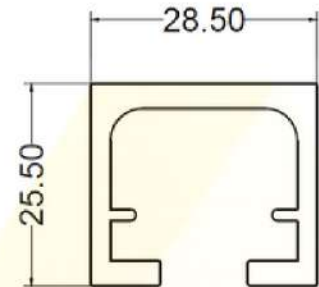

Section : AMI-348

W : 0.698 Kg/m
P : 184.70 mm

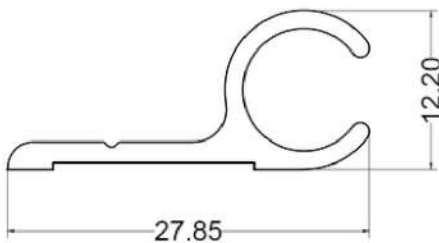

Section : AMI-8738

W : 0.202 Kg/m
P : 94.054 mm



All Metal Industries

Geometric Sections
Stocked Products

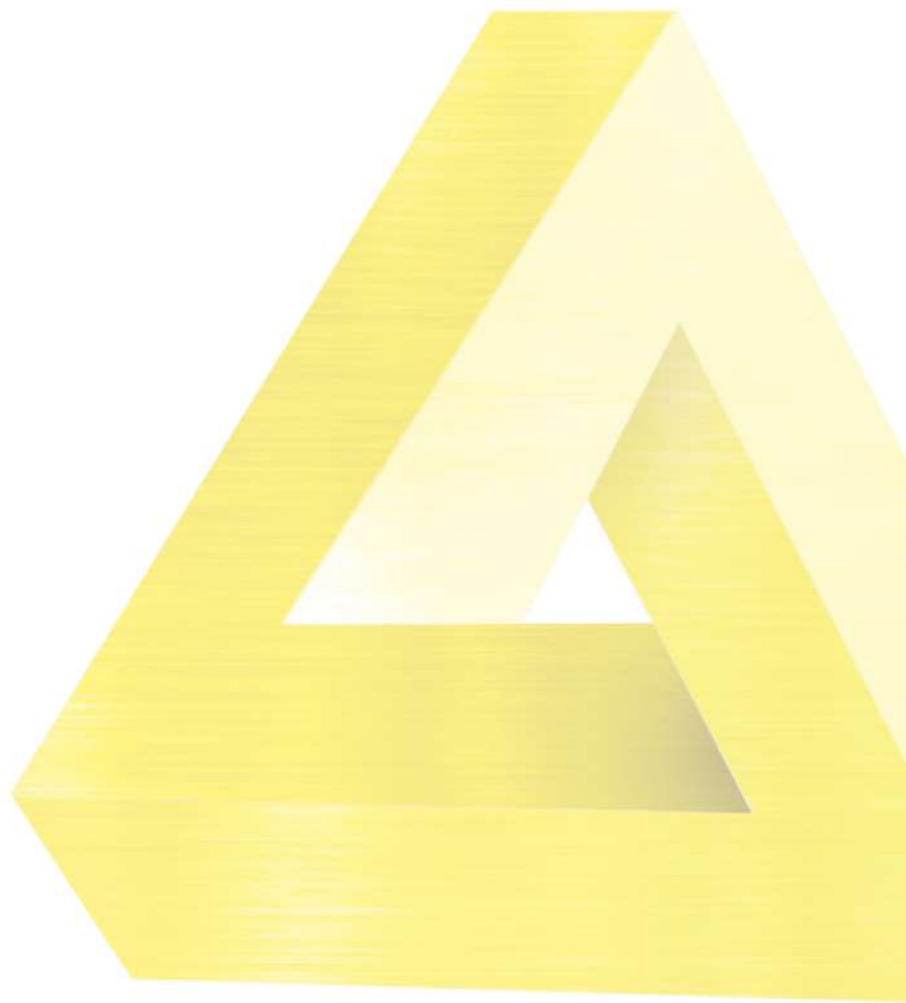



Flat Bar

| Section Code | Size | Weight per/M | Perimeter | Length (M) |
|--------------|----------|--------------|-----------|------------|
| AMI-1318 | 25 x 3 | 0.203 | 56.00 | 4.0 |
| AMI-10010 | 40 x 6 | 0.650 | 92.00 | 4.0 |
| AMI-1332 | 40 x 10 | 1.084 | 100.00 | 4.0 |
| AMI-1335 | 50 x 3 | 0.406 | 105.50 | 4.0 |
| AMI-1336 | 50 x 6 | 0.814 | 112.00 | 4.0 |
| AMI-8252 | 50 x 8 | 1.084 | 116.00 | 4.0 |
| AMI-1337 | 50 x 10 | 1.355 | 120.00 | 4.0 |
| AMI-1356 | 100 x 3 | 0.813 | 206.00 | 4.0 |
| AMI-1358 | 100 x 10 | 2.710 | 220.00 | 4.0 |
| AMI-1060 | 100 x 20 | 5.420 | 240.00 | 4.0 |



U-Channel

| Section Code | Size | Weight per/M | Perimeter | Length (M) |
|--------------|----------------|--------------|-----------|------------|
| AMI-1939 | 20 x 20 x 1.5 | 0.232 | 117.00 | 6.5 |
| AMI-002 | 38 x 25 x 1.4 | 0.323 | 173.20 | 6.5 |
| AMI-004 | 53 x 25 x 1.5 | 0.406 | 203.00 | 6.5 |
| AMI-005 | 78 x 38 x 1.5 | 0.614 | 229.00 | 6.5 |
| AMI-003 | 103 x 38 x 1.5 | 0.715 | 355.00 | 6.5 |



Round Solid

| Section Code | Size | Weight per/M | Perimeter | Length (M) |
|--------------|------|--------------|-----------|------------|
| AMI-1482 | 12mm | 0.320 | 37.70 | 4.0 |
| AMI-1483 | 16mm | 0.545 | 50.27 | 4.0 |



Tee Bar

| Section Code | Size | Weight per/M | Perimeter | Length (M) |
|--------------|---------------|--------------|-----------|------------|
| AMI-1690 | 50 x 25 x 1.6 | 0.318 | 150.00 | 6.5 |
| AMI-2488 | 75 x 25 x 1.6 | 0.545 | 200.00 | 6.5 |



Square Solid

| Section Code | Size | Weight per/M | Perimeter | Length (M) |
|--------------|---------|--------------|-----------|------------|
| AMI-1115 | 12 x 12 | 0.390 | 40.00 | 4.0 |



Radius SHS

| Section Code | Size | Weight per/M | Perimeter | Length (M) |
|--------------|---------------|--------------|-----------|-----------------|
| AMI-095 | 20 x 20 x 1.6 | 0.314 | 77.25 | 6.5 |
| AMI-1638 | 25 x 25 x 1.6 | 0.404 | 98.28 | 6.5 |
| AMI-2784 | 30 x 30 x 1.5 | 0.448 | 114.85 | 6.5 |
| AMI-1651 | 40 x 40 x 3 | 1.140 | 149.70 | 6.5 |
| AMI-1655 | 50 x 50 x 2 | 0.990 | 189.70 | 1.8 - 2.1 - 6.5 |
| AMI-1656 | 50 x 50 x 3 | 1.466 | 189.70 | 1.8 - 2.4 - 6.5 |
| AMI-1666 | 65 x 65 x 3 | 2.009 | 251.40 | 2.4 - 6.5 |
| AMI-287 | 100 x 100 x 3 | 3.175 | 399.99 | 3 - 6.5 |



Square Edge SHS

| Section Code | Size | Weight per/M | Perimeter | Length (M) |
|--------------|---------------|--------------|-----------|------------|
| AMI-1236 | 40 x 40 x 1.6 | 0.667 | 160.00 | 6.5 |
| AMI-1238 | 40 x 40 x 3 | 1.199 | 159.50 | 6.5 |
| AMI-1242 | 50 x 50 x 2 | 1.040 | 200.00 | 6.5 |
| AMI-1243 | 50 x 50 x 3 | 1.523 | 200.00 | 6.5 |
| AMI-1252 | 75 x 75 x 3 | 2.341 | 300.00 | 6.5 |
| AMI-1255 | 100 x 100 x 3 | 3.143 | 400.00 | 6.5 |



Radius RHS

| Section Code | Size | Weight per/M | Perimeter | Length (M) |
|--------------|----------------|--------------|-----------|------------|
| AMI-1601 | 38 x 16 x 1.2 | 0.322 | 102.85 | 6.5 |
| AMI-2883 | 38 x 25 x 1.5 | 0.473 | 120.85 | 6.5 |
| AMI-1603 | 65 x 16 x 1.2 | 0.498 | 156.90 | 6.5 |
| AMI-219 | 65 x 50 x 3 | 1.710 | 219.70 | 6.5 |
| AMI-012 | 100 x 16 x 1.2 | 0.770 | 226.85 | 6.5 |
| AMI-008 | 100 x 50 x 3 | 2.279 | 289.70 | 6.5 |



Square Edge RHS

| Section Code | Size | Weight per/M | Perimeter | Length (M) |
|--------------|-------------------|--------------|-----------|------------|
| AMI-2890 | 40 x 20 x 3 | 0.878 | 120.00 | 6.5 |
| AMI-0001 | 50 x 25 x 2 | 0.770 | 150.00 | 6.5 |
| AMI-1188 | 60 x 40 x 3 | 1.530 | 199.48 | 6.5 |
| AMI-1181 | 76.2 x 25.4 x 2.4 | 1.255 | 203.20 | 6.5 |
| AMI-1195 | 75 x 50 x 3 | 1.930 | 250.00 | 6.5 |
| AMI-1189 | 80 x 40 x 3 | 1.854 | 240.00 | 6.5 |
| AMI-1172 | 100 x 25 x 2.5 | 1.626 | 250.00 | 6.5 |
| AMI-1199 | 100 x 50 x 3 | 2.342 | 299.31 | 6.5 |
| AMI-1202 | 150 x 50 x 3 | 3.155 | 400.00 | 6.5 |
| AMI-1203 | 200 x 50 x 3 | 3.967 | 500.00 | 6.5 |



Angles

| Section Code | Size | Weight per/M | Perimeter | Length (M) |
|--------------|---------------|--------------|-----------|------------|
| AMI-1376 | 20 x 20 x 1.6 | 0.166 | 79.40 | 6.5 |
| AMI-1381 | 25 x 25 x 1.6 | 0.21 | 100.00 | 6.5 |
| AMI-1436 | 32 x 20 x 1.6 | 0.218 | 104.00 | 6.5 |
| AMI-1388 | 32 x 32 x 1.6 | 0.271 | 128.00 | 6.5 |
| AMI-036 | 35 x 35 x 2 | 0.369 | 140.00 | 6.5 |
| AMI-1395 | 40 x 40 x 3 | 0.626 | 159.40 | 6.5 |
| AMI-519 | 50 x 50 x 3 | 0.789 | 200.00 | 6.5 |
| AMI-1402 | 50 x 50 x 6 | 1.53 | 200.00 | 6.5 |
| AMI-1447 | 70 x 40 x 1.5 | 0.441 | 220.00 | 6.5 |
| AMI-1451 | 100 x 50 x 3 | 1.195 | 300.00 | 6.5 |



Round Tube

| Section Code | Size | Weight per/M | Perimeter | Length (M) |
|--------------|-------------|--------------|-----------|------------|
| AMI-1267 | 16 x 1.2 | 0.151 | 50.27 | 6.5 |
| AMI-1270 | 19 x 1.6 | 0.237 | 59.69 | 6.5 |
| AMI-1288 | 40 x 3 | 0.946 | 125.66 | 6.5 |
| AMI-1293 | 50 x 3 | 1.202 | 157.08 | 6.5 |
| AMI-8523 | 101.6 x 1.6 | 1.362 | 319.19 | 6.5 |





All Metal Industries

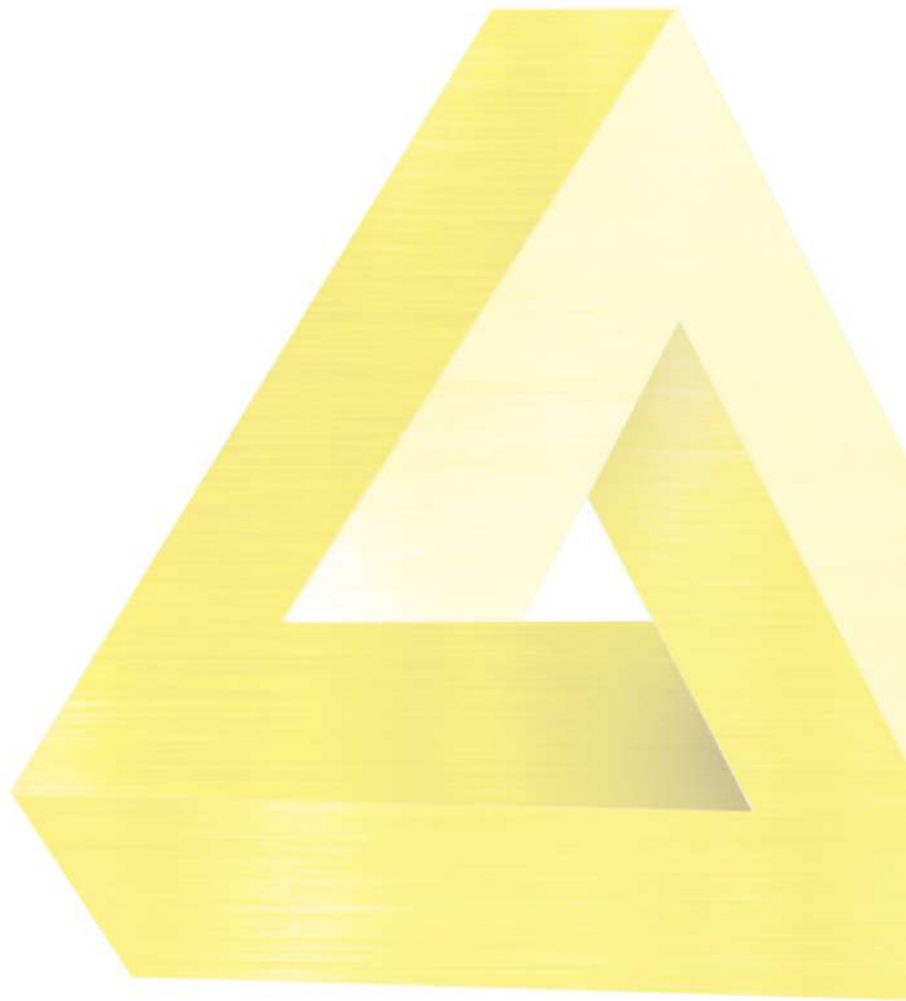

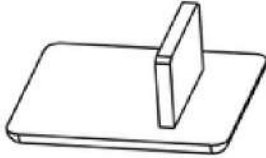
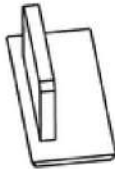
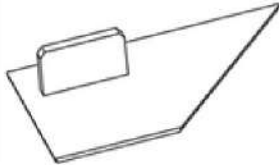

Castings, Endcaps and Brackets
Stocked Products

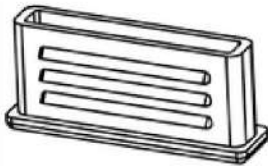
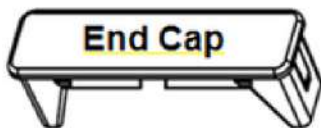



| Product Description | Product Image | Item Code | Product Size | Colour / Material |
|--|---|------------------|---|-------------------------|
| 65x16x1.2 Angle Bracket (LH & RH Needed) |  | AMI-6515LVR | 65 x 16 x 1.2mm To Suit AMI-1603 | Black Plastic |
| | | | | Pearl White Plastic |
| Fence U Channel Top/Bottom Cover |  | AMI-PLCAP | 26 x 30 To Suit AMI-129 (Fencing Channel) | Black Plastic |
| Slat Support Top/Bottom Cover |  | AMI-SLATSUPP-CAP | 25 x 11.5 To Suit AMI-163 (Slat Support) | Black Plastic |
| Fence 135d U Channel Top/Bottom Cover |  | AMI-135DG | 55 x 30 To Suit AMI-175 (135d Channel) | Black Plastic |
| Operable 88mm Louvre Blade Clip |  | AMI-88mm-Lclip-B | 88mm To Suit AMI-227 (88mm Louvre Blade) | Black Plastic |
| | | AMI-88mm-Lclip-W | 88mm To Suit AMI-227 (88mm Louvre Blade) | Pearl White Plastic |
| Plastic End Cap |  | AMIPL - 502D | 50 x 50 x 2 Dome | Black Plastic |
| | | AMIPL - 503 | 50 x 50 x 2 & 3mm | |
| | | AMIPL - 653 | 65 x 65 x 3 | |
| | | AMIPL - 100503 | 100 x 50 x 3 | |
| | | AMIPL - 10103 | 100 x 100 x 3 | |
| | | AMIPL - 15503 | 150 x 50 x 3 | |
| Slat Plastic Endcap |  | AMI-38-ENDCAP | 38 x 16 x 1.2mm To Suit AMI-1601 | Black Plastic / Colours |
| | | AMI-65ENDCAP | 65 x 16 x 1.2mm To Suit AMI-1603 | |
| | | AMI-100ENDCAP | 100 x 16 x 1.2mm To Suit AMI-012 | |
| Aluminium Casting End Cap |  | AMI1665CAST | 65 x 16 x 1.2mm To Suit AMI-1603 | MF Aluminium Casting |
| | | AMI16100CAST | 100 x 16 x 1.2mm To Suit AMI-012 | |
| | | AMI - 76.2CAST | 76.2 x 25.4 x 2.4mm To Suit AMI-1181 | |

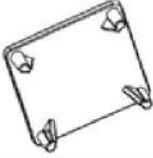
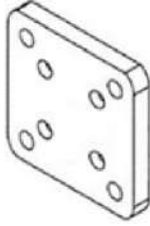
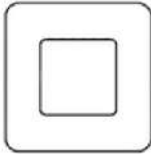
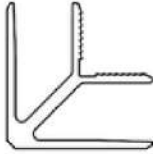
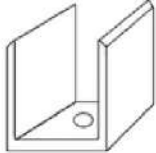

| Product Description | Product Image | Item Code | Product Size | Colour / Material |
|---|---|---------------|--|------------------------|
| Aluminium Spear "Fleur De Lis" Female |  | AMI-F-MB19 | 102mm To Suit AMI-1270 (19mm Round Tube) | MF Aluminium Casting |
| Aluminium Picket "Sovereign" Male |  | AMI-SOVEREIGN | 72mm To Suit AMI-1603 (65x16x12mm RHS) | MF Aluminium Casting |
| Aluminium Spear "Centine" Female |  | AMI-M-OB16 | 148mm To Suit AMI-1267 (16mm Round Tube) | MF Aluminium Casting |
| | | AMI-M-OB19 | 148mm To Suit AMI-1270 (19mm Round Tube) | |
| Single Lug Bracket |  | AMI-FB30P | 30x30 To Suit AMI-2784 (30x30mm SHS) | MF Aluminium Casting |
| | | AMI-FB38P | 38x25 To Suit AMI-2883 (38x25mm SHS) | |
| | | AMI-FB40P | 40x40 To Suit AMI-1238 (40x40mm SHS) | |
| 50x50mm End Cap |  | AMI-FAB1002 | 50 x 50mm To Suit AMI-8861 (50x50 Screw Flute Post) | MF Aluminium Casting |
| | | | | Powdercoated Aluminium |
| 100x100mm Base Plate |  | AMI-FAB1001 | 100 x 100mm To Suit AMI-8861 / AMI-162 (50x50 Screw Flute Post) | MF Aluminium |
| | | | | Powdercoated Aluminium |
| | | | | Timber Grain |
| 100x100mm Dress Ring |  | AMI-FAB1003 | 100 x 100 To Suit AMI-162 (50x50 Post) | Mill Finish Aluminium |
| Gate Frame Corner Stake |  | AMI-9584 | 90x90 To Suit AMI-1238 (Gate Frame corner) | MF Aluminium |
| Concealed Channel Fixing Bracket |  | AMI-9519 | 50x50 To Suit AMI-1242 (50x50x2 SHS) | MF Aluminium |



All Metal Industries

**Gate Hardware
Stocked Products**

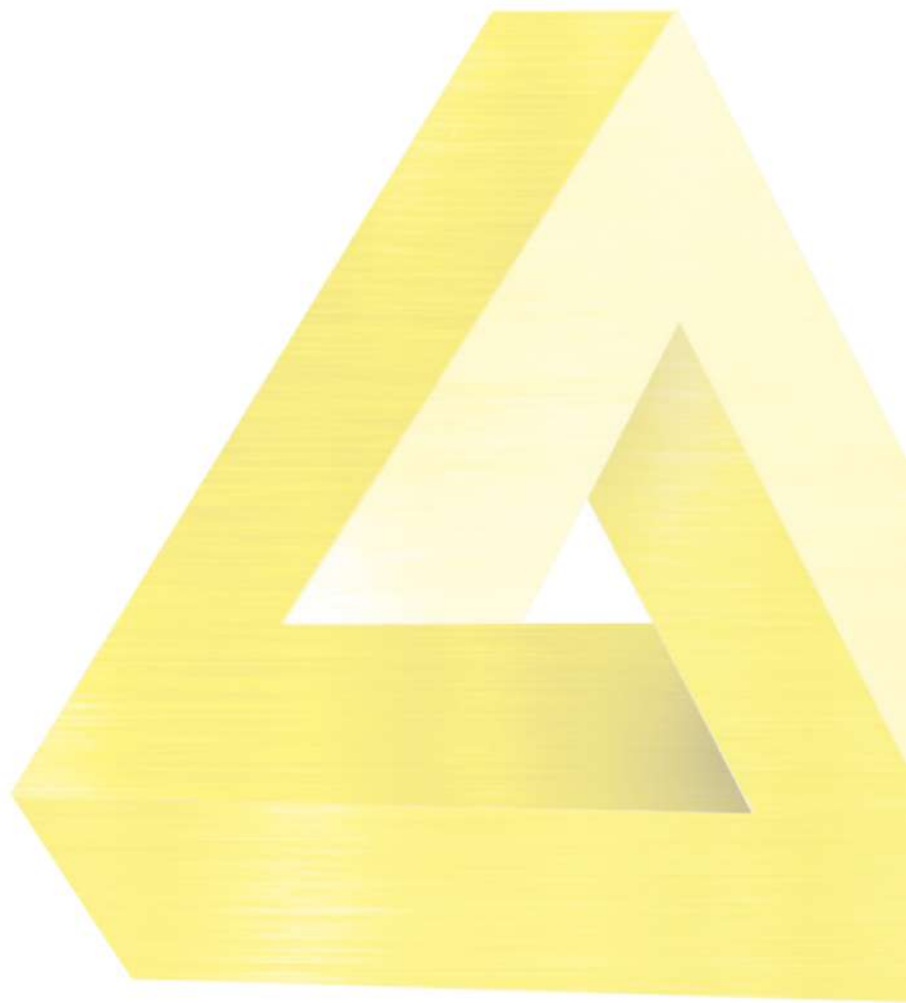



| Product Description | Product Image | Item Code | Product Size | Colour / Material |
|--|---|----------------------|--|--------------------------|
| Sliding Gate Nylon Block |  | AMI-S-NBLOCK | 76 x 74 x 62mm To Suit AMI-2567/AMI-2567 | Black Plastic |
| | | | | Pearl White Plastic |
| 6 EYE Automatic Gate Gear Rack |  | AMI-Gate Gear Rack | 1000mm | Black Nylon Coated Steel |
| Lokklatch Keyd Alike (Deluxe) |  | AMI-LATCH | Privacy and Security Gate Latch (Key'd Alike) | Black Plastic |
| Lokklatch Individual keys (Deluxe) |  | AMI-LATCH KEYD ALIKE | Privacy and Security Gate Latch | Black Plastic |
| D&D Kwikfit Self Closing Hinge With Legs |  | AMI-KWIKFIT | To suit self-closes gates up 20kg | Black Plastic |
| D&D TRUCLOSE Heavy Duty Hinge NO LEGS |  | AMI-GATE-HD | To suit self-closes gates up 30kg | Black Plastic |
| D&D TRUCLOSE Regular Hinge NO LEGS |  | AMI-GATE-RD | To suit self-closes gates up 70kg | Black Plastic |



All Metal Industries

**Gate Automation
Stocked Products**

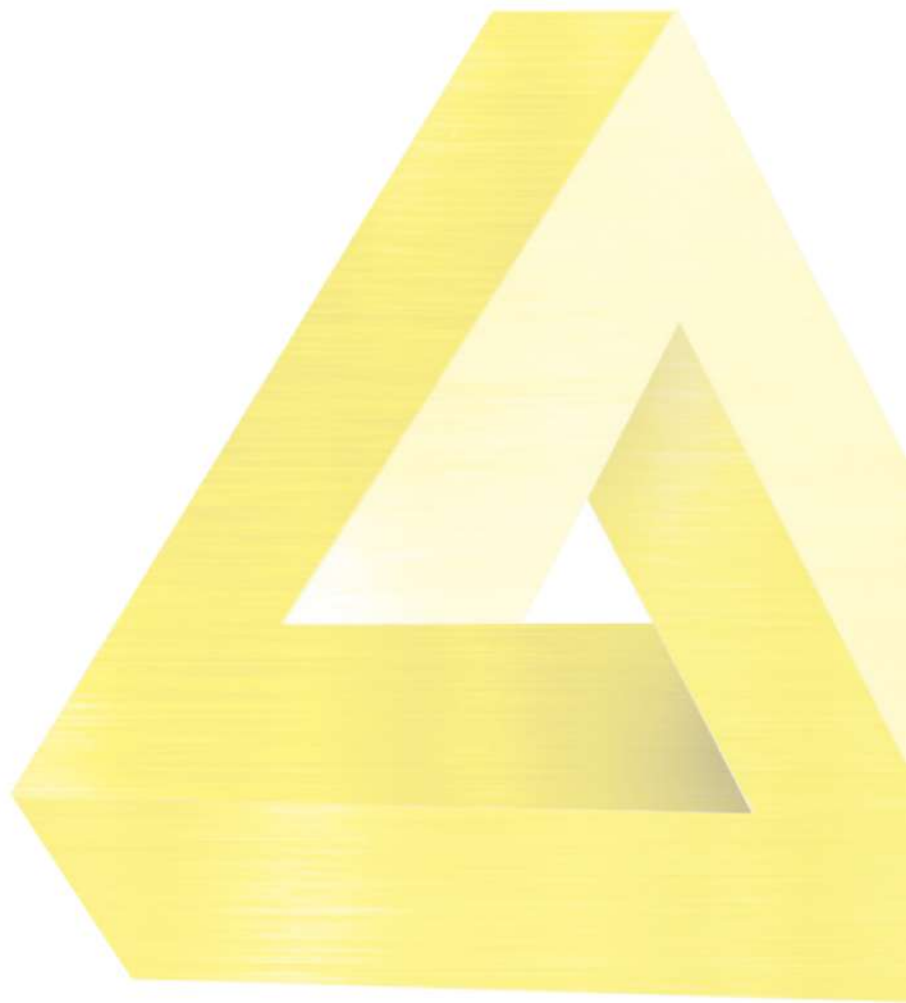



| Product Description | Product Image | Item Code | Product Kit Inclusions |
|--|---------------|-----------------|--|
| CENTSYS D5-EVO (500KG) Kit - Domestic And Light Industrial Applications | | AMI-D5 EVO KIT | D5-EVO 500KG 240V INPUT (12V DC System) PCB, 1.8A SM Charger, Multichannel Nova Receiver, 2 X Four button transmitters, Chronoguard Timer. Includes Battery and Rack |
| CENTSYS D10 (1000KG) Kits - Commercial And Industrial Application | | AMI-D10 EVO KIT | D10 1000KG Commercial Operator 240V Input (24V DC System) PCB, Charger, Multichannel Nova Receiver, Chronoguard Timer. Includes Remotes, Batteries and Rack. |
| CENTSYS Vantage 400 Operator (SINGLE) KIT | | AMI-V400SINGLE | Vantage 400 - 12V DC Linear Operator With Pistondrive- Stroke 500MM, 240V Input (Standard) V-Series Wallbox Including: Controller, Multichannel Receiver, 2 X Four Button Transmitters, 1.8A SM Charger, Mains Isolater, Battery 12V, 7.2AH- Sealed Maintenance Free |
| CENTSYS Vantage 400 Operator (DOUBLE) KIT | | AMI-V400DOUBLE | Vantage 400 - 12V DC Linear Operator With Pistondrive- Stroke 500MM, 240V Input (Standard) V-Series Wallbox Including: Controller, Multichannel Receiver, 2 X Four Button Transmitters, 1.8A SM Charger, Mains Isolater, Battery 12V, 7.2AH- Sealed Maintenance Free |
| CENTSYS Vantage 500 Operator (SINGLE) KIT | | AMI-V500SINGLE | Vantage 500 - 12V DC Linear Operator With Pistondrive- Stroke 500MM, 240V Input (Standard) V-Series Wallbox Including: Controller, Multichannel Receiver, 2 X Four Button Transmitters, 1.8A SM Charger, Mains Isolater, Battery 12V, 7.2AH- Sealed Maintenance Free |
| CENTSYS Vantage 500 Operator (DOUBLE) KIT | | AMI-V500DOUBLE | Vantage 500 - 12V DC Linear Operator With Pistondrive- Stroke 500MM, 240V Input (Standard) V-Series Wallbox Including: Controller, Multichannel Receiver, 2 X Four Button Transmitters, 1.8A SM Charger, Mains Isolater, Battery 12V, 7.2AH- Sealed Maintenance Free |



All Metal Industries

Processing hardware
Stocked Products

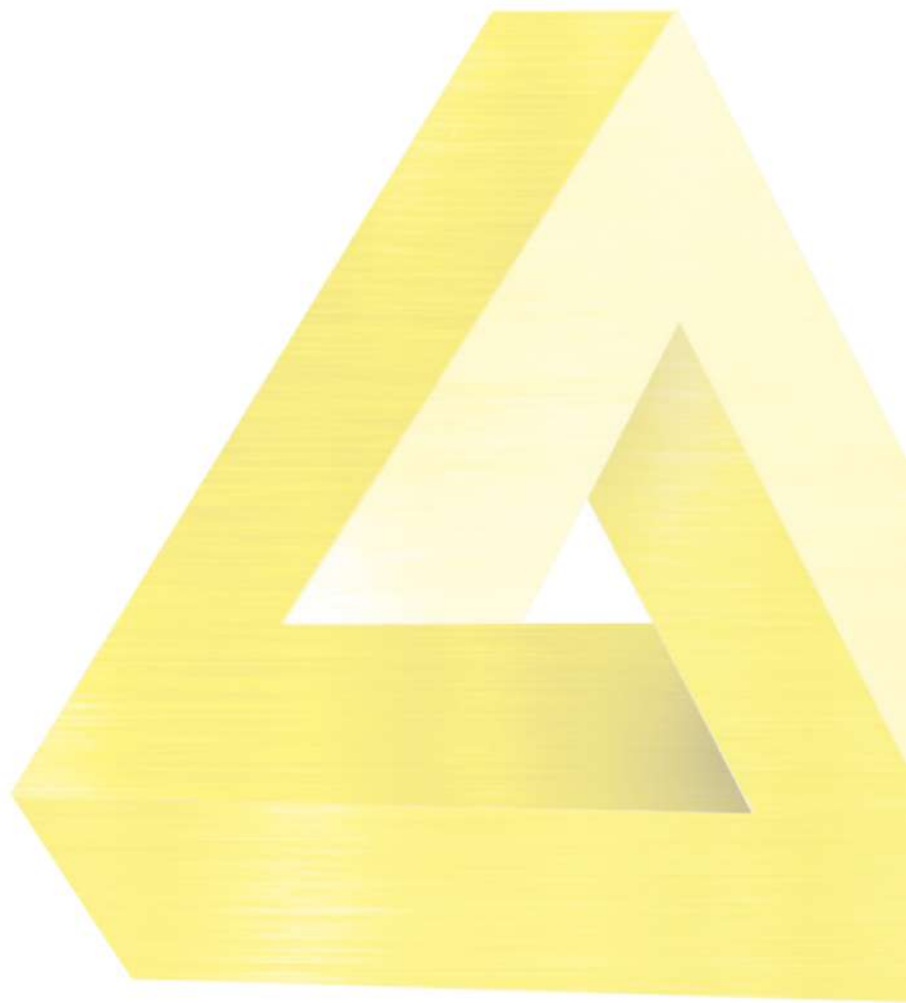



| Product Description | Product Image | Item Code | Product Size | Colour / Material |
|-------------------------------|---------------|-------------|------------------|-------------------|
| Aluminium Saw Blade | | AMI-Saw255 | 255mm (80T) | Tungsten Carbide |
| Aluminium Saw Blade | | AMI-Saw305 | 305mm (96T) | Tungsten Carbide |
| Aluminium Saw Blade | | AMI-Saw355 | 355mm (120T) | Tungsten Carbide |
| Aluminium Up-Spiral CNC Piece | | AMI-CNC6126 | 6mm x 12mm x 6mm | Tungsten Carbide |
| Aluminium Up-Spiral CNC Piece | | AMI-CNC6256 | 6mm x 25mm x 6mm | Tungsten Carbide |



All Metal Industries

Timber Colour Range
Stocked Products

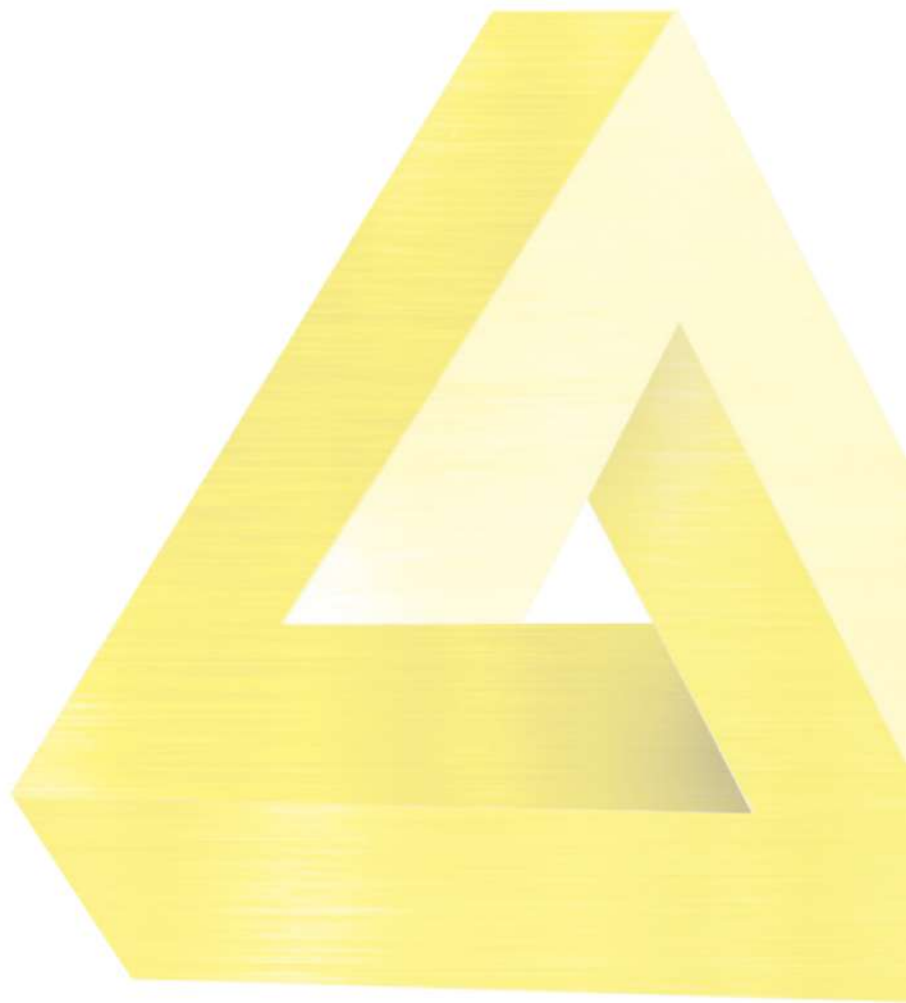



Beach oak



Wild Olive



Western Cedar



Jarrah



DISCLAIMER

Whilst care was taken in the preparation of the data contained in this handbook, All Metal Industries accepts no liability for the accuracy of information supplied and should be used as a guide only.

TERMS & CONDITIONS OF SALE

A full copy of All Metal Industries Terms & Conditions of Sale document is available on request.

PRODUCT WARRANTY

All Metal Industries warrants the quality of our products. Warranty liability extends to the value of the product supplied or the replacement of only, at All Metal Industries option. All Metal Industries does not accept any claim for consequential loss.

Date : OCTOBER 2023





TALK TO US

 **(08) 6455 0200**

 ***Sales@allmetalindustries.com.au***

 ***11 Yelland Way, Bassendean, Western Australia 6054***